

PlanGridEV

Distribution grid planning and operational principles for electric vehicle mass roll-out while enabling integration of renewable distributed energy resources

The research leading to these results has received funding from the European Union Seventh Framework Programme (FP7/2007–2013) under Negotiation No. 608957.

Foreword



Distribution grid planning and operational principles for EV mass roll-out while enabling DER integration

Project duration June 2013 – February 2016
Project budget approx. 7.5 million euro
Funding by EC approx. 4.8 million euro
Project team 12 Partners from nine different countries



Developing reliable, flexible energy distribution to embrace energy transformation

The requirements for electricity distribution are expanding rapidly. This is being driven by two dominant factors: first, the energy needs of dynamic market for electric mobility; secondly, the growing renewable energy sector. To put the latter in perspective, last year wind energy in Germany grew by 46 percent compared to the previous year. Overall, the share of renewables in Germany rose by 19.4 percent. But what happens when the consumption from e-mobility and the feed-in from renewable energy sources increase, but not in harmony? Is our existing network able to meet these expectations while conserving energy resources, remaining strong and secure and running efficiently?

To develop our distribution network in a way that is reliable and flexible is one of the challenges brought about by this energy transformation. Numerous flagship projects have been raising awareness and putting this issue in the spotlight. But the federal government in Germany and the European Union are increasingly demanding a common strategy for all of Europe – and fast. That’s why it was crucial for us, from the outset, to deliver an implementable, transnational PlanGridEV project with notable successes.

From the beginning, the goal has been not only to make recommendations and devise model solutions but to succeed together in providing a toolbox so that network operators and infrastructure users can, hammer and nail in hand, not only look at the picture of a stable distribution network, but be able to hang it on the wall.

After three years, many studies, numerous publications and public presentations we are proud to introduce for the first time, a transparent and binding way for the planning and operation of a smart grid. Our sincere thanks go to all 12 strong partners from industry and research for their part in a project that has seen a total of nine countries come together with their specific expertise and extensive market experience. My special thanks also go to the European Commission, which has supported and promoted PlanGridEV. The growing demands on the distribution network will increasingly continue to accompany us in everyday life. We are convinced that we can look forward together with science and industry, energy suppliers and end-users towards a strong, sustainable distribution network that can manage this energy transition.

Dr. Andreas Breuer

Head of New Technologies and Projects, RWE Deutschland

Source for the renewable growth figures: gross national electricity production, BMWi 2016



Table of contents



Foreword	2
Table of contents	4
List of abbreviations	6
Executive Summary	8
Challenges for distribution grids	10
PlanGridEV objectives	12
Exchange of knowledge with other projects	14
Partners	16
Events	18
D1.1 Current requirements	20
D1.2 Future scenarios	22
D1.3 KPI report	23
D1.3 Gap analysis	24
D1.4 State-of-the-art methods	26
D2.1 EV grid integration business scenarios	28
D2.2 Technical requirements for tools/methods for smart grid integration of EVs	30
D2.3 Economic tools for smart-grid integration of EVs	31



D3.1	Network architecture model	32
D3.2	Specification of energy grid/Functional and service architecture	33
D3.3	New ICT developments and services for EV integration in electricity distribution networks	34
D4.1	Definition of the optimisation problem and tools specifications	36
D4.2	Methods to maximise the integration of EV and DER in distribution grids	37
D4.5	Prototype tool for optimising existing assets and grid planning using controllable loads	38
D4.5	ICT model of planning tool	40
D5.1	Selection of use cases and testing infrastructure at DSOs	42
D5.2	Infrastructure and system updates	43
D5.3	Validation and real testing	44
D6.1	Optimised and enhanced grid architecture for electric vehicles in Europe	46
D6.2	Analysis and performance evaluation as a basis for further recommendations	48
D6.3	Findings from simulation	50
D6.3	Novel planning rules for EV in smart grids	54
D7.1	EV-Grid integration best scenario and investment strategies	56
D7.2	Roadmap and recommendations over innovation, regulation and policies	58
	PlanGrid EV deliverables	60



List of abbreviations



AC	Alternating Current
ADMS	Advanced Distribution Management System
AMI	Advanced Metering Infrastructure
AMR	Automated Meter Reading
BAU	Business As Usual
CAPEX	Capital Expenditures
CHP	Combined Heat and Power
CO₂	Carbon Dioxide
CPP	Critical Peak Pricing
DA	Distribution Automation
DC	Direct Current
DER	Distributed Energy Resource
DG	Distributed Generation
DIN	Deutsche Industrie Norm – German Industry Standard
DMS	Distribution Management System
DR	Demand Response
DS	Distributed Storage
DSM	Demand Side Management
DSO	Distribution System Operator

EC	European Commission
EEGI	European Electricity Grid Initiative
EGCI	European Green Car Initiative
EMM	Enel Mobility Management system
EU	European Union
EV	Electric Vehicle
EVSE	Electric Vehicle Supply Equipment
EVSEO	Electric Vehicle Supply Equipment Operator
EVSP	Electric Vehicle Service Provider
GPRS	General Packet Radio Service
GSM	Global System for Mobile Communications
HEC	Home Energy Controller
HV	High Voltage
ICT	Information and Communication Technology
IEC	International Electrotechnical Commission
IEEE	Institute of Electrical and Electronics Engineers
IEN	Intelligent Energy Network



IF	Interface
IP	Internet Protocol
ISO	International Organization for Standardization
IT	Information Technology
KPI	Key Performance Indicator
LAN	Local Area Network
LTE	Long-Term Evolution (mobile technology)
LV	Low Voltage
MV	Medium Voltage
OEM	Original Equipment Manufacturer
OPEX	Operational Expenditures
OPF	Optimal Power Flow
OSCP	Open Smart Charging Protocol
PGEV	PlanGridEV EU project
PLC	Power Line Carrier communication
PV	Photovoltaic
PWM	Pulse-width modulation
REN	Renewable Energy Resources
RES	Renewable Energy Source

SGAM	Smart Grid Architecture Model
SGCP	Simple Gateway Control Protocol
TCO	Total Cost of Ownership
TFO	Transformer
TRL	Technology Readiness Level
TSO	Transmission System Operator
TSO	Transmission System Operator
UC	Unified Communication
UMTS	Universal Mobile Telecommunications System
WAN	Wide Area Network



Executive Summary

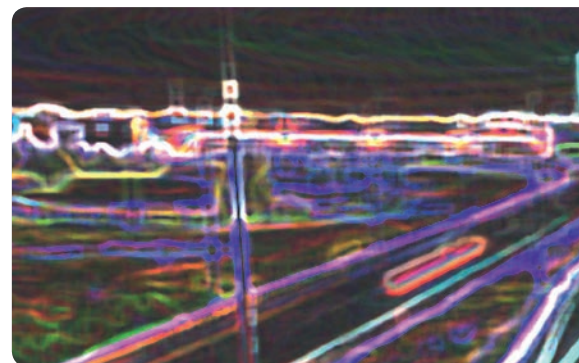

The mass roll-out of electro-mobility, in conjunction with the increased production of electricity derived from renewable sources like wind and photovoltaics, is one of the major opportunities to reduce CO₂ over the next decade. The efficiency of electric engines is superior to that of combustion engines and the renewable energy sources used to power them are naturally CO₂-free. Additionally, the fact that electric cars use batteries takes care of the issue of energy storage, helping to overcome the problem of renewable sources only being available when the sun is shining or the wind is blowing. The battery in the car, in combination with an energy management system that can monitor the availability of renewable energy, is a major opportunity.

The challenge of these two growing movements is the requirement for large scale interaction between energy supply and demand. While this is a well-known balance in need of management in industrial production plants, it has never been applied at grid level. Moreover, the fact that the controlled loads (electric vehicles (EVs) in this case) are moving around and are only connected to the grid from time to time has never previously been taken into account. To date, there have been no grid planning tools designed to meet these opportunities and challenges.

The new hurdle for grid planning is that although the grid extension needed to provide the energy for EVs is actually rather small, the power need, especially for fast charging, is substantial. In the end, it's not only the delivery of the energy that is the problem but the power itself. While replacing all cars with conventional drive technology with electric cars would call for just an additional 18% energy, the delivery of the power might depend on the charge scheme in use: fast versus grid-friendly.

Challenges arising from this are line loading issues and voltage as well as the necessary introduction of ICT in the low voltage (LV) and medium voltage (MV) grids.

To overcome these challenges, the EC funded project 'PlanGridEV' has developed a totally new planning approach for distribution grids, implemented via a prototype tool. Instead of simply considering the estimated peak load of the grid, as with traditional distribution grid planning, the PlanGridEV approach additionally considers the controllability of the loads in conjunction with the estimated generation from renewable sources. Some PlanGridEV synthetic models for the major components of car movement and charging, wind generation, PV generation and storage have been developed and integrated. The new planning tool takes into account not only one peak load day but stochastic behaviour over a several month planning horizon. Additionally an ICT communication model has been developed and integrated to derive the necessary ICT components for a certain implementation.

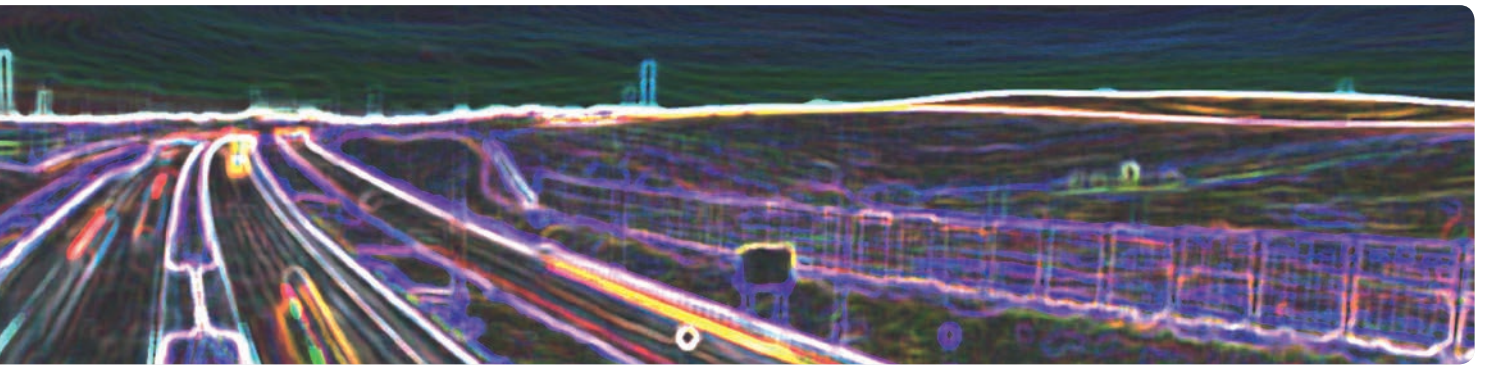

Based on a set of scenarios and use cases (for more or less grid-friendly charging) some calculations have been performed that prove that there are major benefits with the smart grid approach. Depending on the set-up, the peak load could be reduced by half compared to an uncontrolled charging scenario. Furthermore the usage of renewable energy could be increased without interfering with transportation needs. This clearly shows that in an all-electric world the smart grid approach will play a major role.

But there are still more challenges to be solved. The integration of additional ICT in electrical grids will lead to a major change in the way a secure grid will operate. To build a grid that is incapable of the theoretical peak load if the ICT systems fail, is an approach that contradicts historic thinking in electrical distribution. It calls for new operational procedures. Some such procedures were trialled in the PlanGridEV test beds where it could be demonstrated that they work well. But there are still open issues, including data security and integrity that have to be overcome before a full roll-out.

Additionally, there are operational and regulatory challenges regarding the implementation of new procedures and the introduction of the resulting new market players. Challenges also arise where market roles are not yet defined and where the traditional set-up overlooks a stakeholder function that PlanGridEV's simulations have identified as being necessary.

For example, the Distribution System Operator's (DSO) role is growing in terms of responsibility and required impact as regulation draws a strong border between market, generation and grid business. The PlanGridEV project found technically optimal solutions that showed that the control information about grid status, connected loads and generation play a major role in optimisation. But traditionally it is not a role of the DSO to interact with market players to provide this information in order to implement control schemes. Also, the DSOs seem to be the major beneficiaries, so it has to be decided how investments in the charging infrastructure and the cars will be financed. Again, the DSOs should play an important role in this environment if a new market design is to allow them to do as described and if there is investment in grid intelligence as opposed to in copper and aluminium.

Finally, we have been able to show with our prototype tool, that a new grid planning approach is both feasible and leads to desired results. It could be proved in the simulations and in the test beds that the new approach leads to less expensive grids while providing all the energy the customer needs. In conclusion, we have found a way in which a full roll-out of electric vehicles is feasible. The implementation requires that regulation and the market develop accordingly, with respect to the new functionality that will be available in the coming years.



Challenges for distribution grids

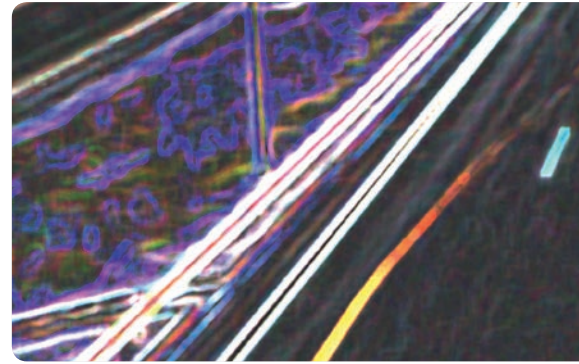

It is estimated that by 2025, about five million electric vehicles will be on the road all over the world, the majority of these in the EU. European climate policies aim to significantly reduce CO₂-emissions from transport by 60 % by 2050 and to reduce the use of “conventionally-fuelled” vehicles in urban transport by 50%. With technological advances and new mobility concepts, as well as a steadily rising oil price, it can be assumed that electromobility in Europe will increase. Simultaneously, the feed-in from DER is also expected to dramatically increase in order to meet the goals of EU and national climate protection policy. Therefore it can be expected that distribution grids will

need to significantly increase their hosting capacity to accommodate fluctuating supply and mobile loads, in such as EVs.

Large-scale EV introduction will moreover only be successful if the expectations of customers are met and current constraints are overcome. This requires further technological development and the intense cooperation of all stakeholders, including OEMs, DSOs and energy service providers, for example in operating a sufficient (fast) charging in network infrastructure.

Dramatically changing environment demands new grid planning rules

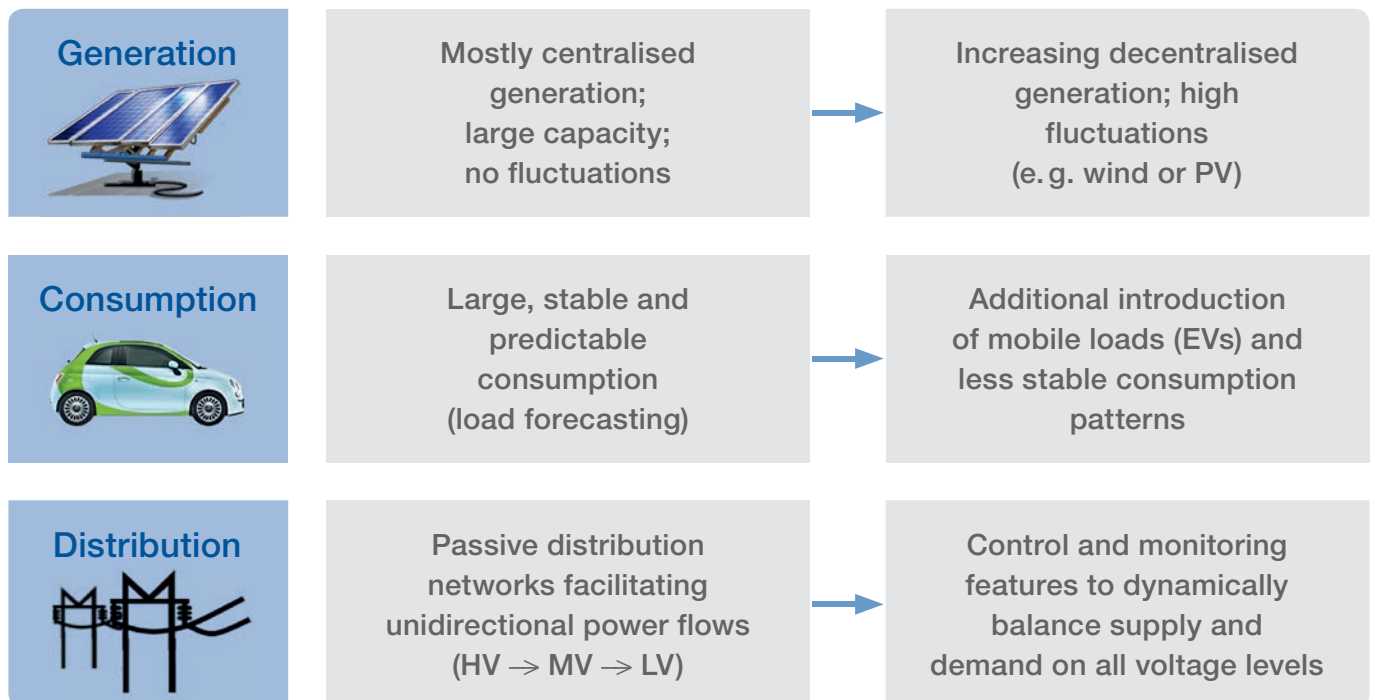

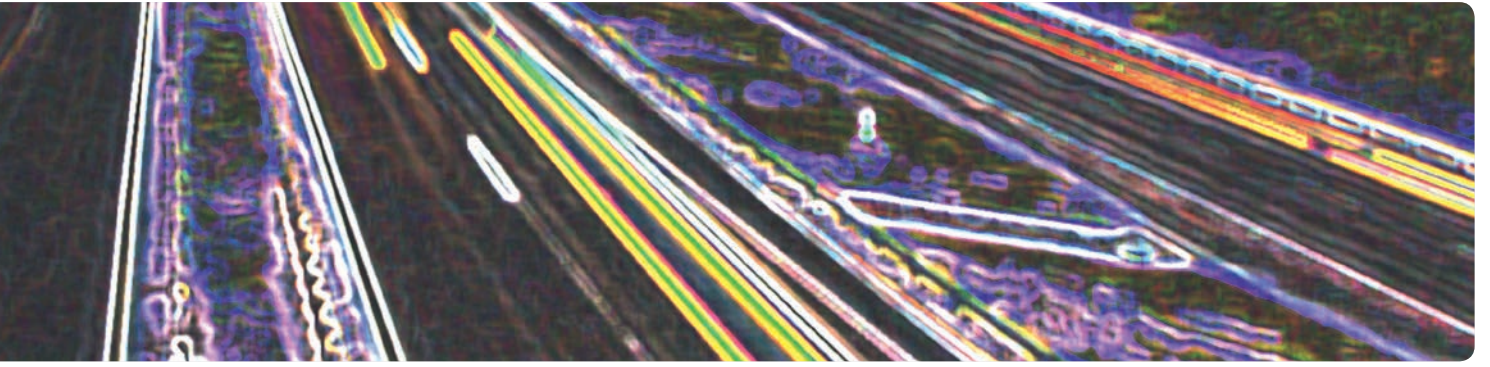

PlanGridEV objectives

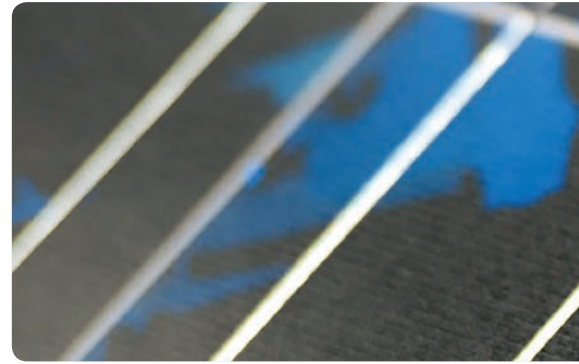

The main objective of PlanGridEV is to design new planning rules and operational principles for the optimal integration of electric vehicles (EVs) for different network topologies and with different levels of distributed energy resource (DER) penetration such as photovoltaics (PV), wind and solar energy and micro combined heat and power generators (CHP).

It aims to identify the key features that future network planning tools should incorporate in order to allow for an adequate assessment of EV demand. It acknowledges an environment characterised by increased uncertainty, but also by greatly improved network management capabilities at the distribution network level.

Tools and methods have been developed that permit Distribution System Operators (DSO) to design new or adapt existing planning rules and investment strategies to ensure technical efficiency and the cost-effective evolution of infrastructures to facilitate the mass roll-out of EVs in networks characterised by different levels of DER penetration. Finally, recommendations for regulatory frameworks and further developed business models are presented.

The overall objective can be broken down into the following five sub-objectives:

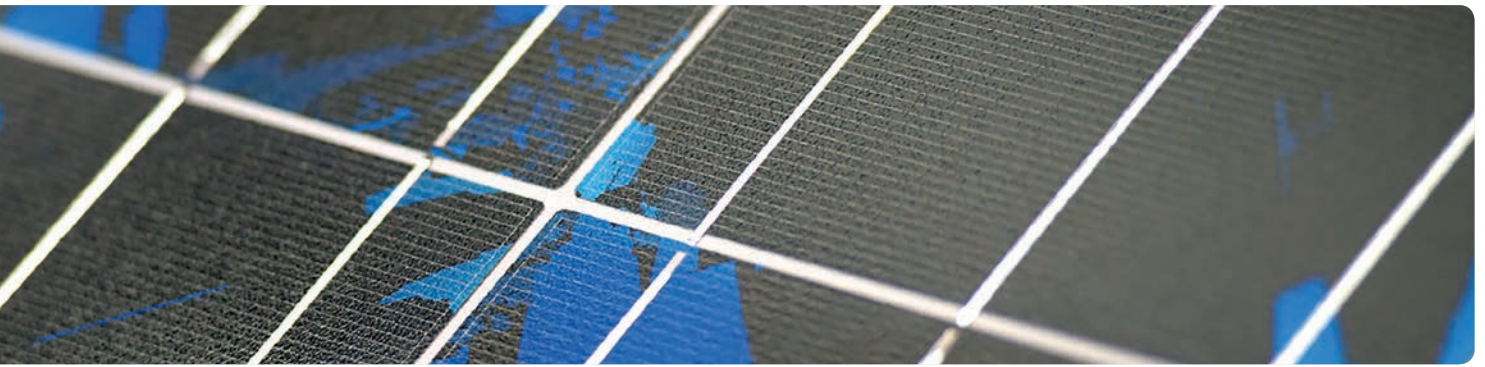

1. Development of tools and methods to design new planning rules involving DSOs/OEMs

Based on a comparative technology and regulatory gap analysis including an assessment of stakeholder needs, methods and tools have been developed to design new planning rules to manage controllable loads, integrate distributed generation and exploit storage options.

2. Development of new planning rules for European DSOs to facilitate the mass roll-out of EVs whilst enabling DER integration

European DSOs are enabled to develop new planning rules to optimise grid planning taking into account the stochastic nature of renewable energy sources and EVs and maximising DER hosting capacities of the distribution network.

3. Updating and validating of operational methods addressing load congestion issues at local level

Methods for network operation are updated, tested and validated in existing EV test beds to address local load and congestion issues.

4. Deriving and updating of investment strategies considering new business models of DSOs and OEMs

Existing DSO investment strategies are updated to enable the creation of investment roadmaps for different scenarios of EV and DER integration taking into account new methodologies for network planning that have been developed in the course of the project. The investment strategies consider different business models and regulatory enhancements needed to support DER integration.

5. Formulation of recommendations regarding the regulatory framework and standardisation efforts

Building on the previous results and the newly outlined planning rules, recommendations for the contribution to on-going standardisation efforts as well as regulatory initiatives are derived.



Exchange of knowledge with other projects

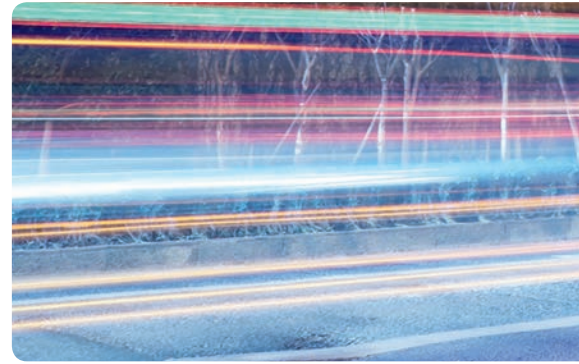

In parallel to the PlanGridEV most of its partners have been actively involved in other European funded projects dealing with similar topics (i. e. Green eMotion, COTEVOS etc.). This has enabled the partners to ensure connection to and close interaction with relevant funding projects especially to EGCI projects and the European Electricity Grid Initiative (EEGI).

After a successful assessment by the corresponding expert group in December 2013 the project PlanGridEV has been awarded the EEGI Support Label.



EEGI is one of the European Industrial Initiatives under the Strategic Energy Technologies Plan (SET-Plan) GRID+. As

it is the coordinator for connecting all relevant smart grid projects in Europe, it is therefore an important platform via which to present PlanGridEV, its ideas and results.

Moreover, Renault, as the coordinator of the EGCI “CAPIRE”, has played a key role as a bridge between the project and the EGCI.

The following table shows the complementary projects that have either already been concluded or are on-going and the corresponding partner, who – as a representative of the respective project – has been responsible for the interaction.

The project partners of the FP7 project COTEVOS and PlanGridEV have agreed a closer cooperation and interaction, by a Memorandum of Understanding.

Some of PlanGridEV’s deliverables have been actively exchanged with other projects (i. e. DISCERN).



Project/Partner	AIT	EDF	EDP	ENEL	ESB	ETH	INESC	La Sapienza	Renault	RWE	Tecnalia	Tractebel	TU Dortmund
ADDRESS		•		•							•		
BUSMOD									•				
CAPIRE											•		
COTEVOS											•		
DISCERN										•			
EcoGRID	•		•								•		
e-DASH									•	•			•
ELVIRE									•				
EMERALD											•		
emporA	•												
eMERGE					•					•			
FENIX		•									•		
G4V		•	•	•						•			
GAD project											•		
Green eMotion		•		•	•		•	•	•	•	•	•	
GRID+	•		•							•	•		
ICT4EVEU									•				
IGreenGrid	•		•	•						•	•		
Inovgrid			•										
IRENE-40						•							
MOBI.e			•		•								
OpenEcosphere										•			•
OSCP									•				
PEGASE												•	
REIVE			•				•						
SiNGULAR			•										
SmartC2Net													•
SmartV2G								•					
SuSTAINABLE			•										



Partners



The consortium is composed of major European players from the energy and automobile sector (DSOs, OEMs) as well as research institutions (universities, research organisations) and engineering consultancies. Their know-how is complementary and safeguards the successful course and outcome of this project. The consortium of PlanGridEV unites partners from different European regions and thereby ensures a holistic European perspective and interdisciplinary approach. The project is led and managed by RWE Deutschland AG as the coordinator of PlanGridEV.



European DSOs



European universities



Research organisation and engineering consultancies



European OEMs



Renault is partner and also member of the OEM Forum.



Daimler, BMW, Nissan and VW are not partners but are collaborating in the OEM Forum.

¹until 31.12.2014



Events



2013

- > **June 11–12, 2013**
PlanGridEV, KickOff-Meeting, Düsseldorf
- > **September 18–20, 2013**
PlanGridEV, 1st OEM-Workshop, Vienna
- > **October 30–31, 2013**
PlanGridEV, Workpackage Leader Board and General Assembly, Brussels

2014

- > **April 9–10, 2014**
PlanGridEV, Workpackage Leader Board and General Assembly, Dublin
- > **June 25, 2014**
PlanGridEV, Workpackage Leader Board, Munich
- > **June 26, 2014**
PlanGridEV, 2nd OEM Workshop, Munich
- > **9–10 September 2014**
PlanGridEV, Workpackage Leader Board and General Assembly, Lisbon
- > **December 2, 2014**
PlanGridEV, Workpackage Leader Board, Brussels



2015

- > **January 29–30, 2015**
PlanGridEV, EC Project Review and Workpackage Leader Board, Brussels
- > **April 15–16, 2015**
PlanGridEV, Workpackage Leader Board and General Assembly, Rome
- > **May 27, 2015**
PlanGridEV, Stakeholder Workshop „Optimized and Enhanced Grid Architecture for Electric Vehicles in Europe”, Brussels
- > **July 22, 2015**
PlanGridEV, Workpackage Leader Board and General Assembly, Brussels
- > **October 21–23, 2015**
PlanGridEV, Workpackage Leader Board and General Assembly, Bilbao,
- > **November 18, 2015**
PlanGridEV, 3rd OEM Workshop “Reverse Charging”, Frankfurt

2016

- > **February 18–19, 2016**
PlanGridEV final event in Brussels
- > **February 18, 2016**
“Leveraging your grid planning strategy”, presentation of the final project results, Brussels
- > **February 19, 2016**
“How to benefit from smart charging”, final presentation of OEM conclusions, Brussels



Current requirements



DSOs network characteristics

Since electric vehicles will present an additional load to the networks, grid reinforcement will be needed. Increasing maximum annual peak loads and voltage constraints will affect investment costs directly. On the other hand, the rise of Distributed Generation (DG) could help mitigate these constraints and eventually reduce proposed grid investments. The pressure on the DSOs' planning process to evolve will increase and become more complex at the same time. Therefore, the correct knowledge of today's "Planning Process" and its criteria will be a major factor in the next phase of this project where new tools and methods will be developed in order to meet the challenges of EV roll out and the expected increase of DER.

Typically the Medium Voltage (MV) networks of the different DSOs present similar characteristics, particularly in the voltage levels used, their construction and the topologies used.

Similar approaches are used by the DSOs in MV network topologies, where two types of topologies are present, closely related by the nature of the load: the radial topology, typically aerial and associated with rural zones, and the mesh topology, typically underground and associated to urban areas. Generally for all the DSOs, the MV radial topology is composed by a main feeder, leaving from an MV bus bar of an HV/MV main substation, which supplies branch clusters of MV/LV secondary substations.

Again the Low Voltage (LV) networks of the different DSOs present similar characteristics in their construction and used topologies. The LV structure in rural zones is typically aerial using bundled cables and fed by pole-mounted transformers. In most cases, in urban areas underground cables are used, fed by ground-mounted transformers, but some aerial bundled cable structures can also be found.

The used HV/MV transformers have a nominal power rating range of between 10 MVA and 63 MVA and are equipped with remote load tap changer in operation. In the MV/LV rural substations, the typical range for the pole mounted MV/LV transformers' nominal power rating is 50 kVA to 250 kVA. In urban areas, substations with pad-mounted transformers are used, where the range is between 250 kVA to 630 kVA.

DSOs planning rules

The planning activity is based on the principle of maintaining the electrical system capacity to meet future demand, while maintaining service quality levels consistent with regulatory requirements and also minimising the environmental impact of the assets. The choice of appropriate planning criteria is important to ensure the progressive improvement of safety standards and the quality of electricity energy distribution, all under criteria for technical and economic efficiency, along with risk analysis and environmental concerns.

Taking into account potential grid investments, the planning criteria must define the network requirements for quality and reliability, and allow gaps in the network to be identified. Costs should be related to the benefits obtained and with the risk scenarios considered. In addition, the planning criteria must establish technical conditions for the connection of new supplies and distributed generation. During the planning period (that varies between DSOs) the future load development has to be forecasted. The corresponding grid reinforcement needs, due to the expected increase on the maximum annual peak loads and voltage constraints, affect the investment costs directly. The profitability of the network projects has to be proved for the economic planning horizon under consideration.

By performing analysis with simulation tools, network insufficiencies are detected. Such deficits are characterised and classified using different parameters such as size,

power at risk and non-supplied energy. The network models and development criteria establish the guidelines to design and define the alternatives that will try to solve the deficiencies detected. These alternatives can consist of expanding the system with minor additions or new network configurations, or can be based on adding new infrastructure to the power system. Examples are new substations with corresponding equipment or new lines. The objective of the “network model” is to minimize the following set, satisfying the DSOs actual planning criteria:

Investment + Operating Costs + Losses + Energy Not Supplied

OEMs

Standards for EVs and their infrastructure are defined in M/468 “Standardisation for road vehicles and associated infrastructure”.

Regarding plug-types, OEMs mainly use IEC 61851/62196 type 1, type 2 or Combo (based on type 2). Some have, on the top of type 1, a ChaDeMo connection (also known as type 4). Some small EVs may have a domestic connector with charge below 2,2 kW. In general, all EVs manufactured by the OEMs who are partners of PlanGridEV

comply with IEC 61851. Although ISO 15118 is not implemented in many commercial cars, the German RWE infrastructure already supports a full ISO 15118 implementation.

One of the main components of an EV is the battery. Current EV models possess battery capacities from 6 to 24 kWh. OEMs foresee the optimisation of battery weight and price before the improvement of battery capacity. However, battery capacity can be expected to reach capacities of around 36 to 40 kWh, mid-term.

Vehicle to grid (V2G) applications (where EVs feed energy back into the grid) are considered by OEMs and DSOs to be a long term option. Due to battery life-time issues and the currently high cost of the charging process, there is no economically feasible business case on the table. Vehicle to home (V2H) technology and a service that already exists in Japan and is highly subsidised.

Overview charging power and main connection of EVs

Power nomination	Main connection	Power in kW	Power in Amps
Normal power	1 – phase AC connection	≤ 3,7 kW	10–16 A
Medium power	1 or 3 phase AC connection	3,7–22 kW	16–32 A
High power AC	3-phase AC connection	> 22 kW	> 32 A
High power DC	DC connection	> 22 kW	> 32 A



Future scenarios



Several road maps and strategies for the European area have been developed and analysed. They stress the need for more regional analysis of electricity systems. There is no one-size-fits-all solution to address the challenges in the electricity sector, and priorities differ among regions. Other related efforts have estimated the prospects for large-scale storage in decarbonised power grids and modeled load shifting using electric vehicles in a smart grid environment.

The scenarios developed by PlanGridEV identify different use cases which derive from the two considered grid voltage levels (LV and MV), the five OEM scenarios and PlanGridEV's business scenarios. Additionally, for the testing and validation process, a basic scenario was introduced as a reference. This basic scenario can be used for either LV or MV grid data due to its focus on the hosting capacity of renewable energy sources (RES). Based on the case, where the individual hosting capacity of a given grid is at 100%, additional capacities of RES can be introduced to create critical situations for challenging the optimisation process of the prototype tool. The allocation of RES, EVs and charging infrastructure is determined by the findings of existing roll-out scenarios, current grid situations and previous project findings. In the case of RES, at LV level, 100% will come from PV systems, whilst at MV level, more than half of the generation of electricity is considered to be from wind turbines, followed by PV and CHP systems.

For the Conventional and Safe scenarios, it is assumed, that concerning the EV market penetration, the lower and rather pessimistic forecasts and roll-out scenarios apply (around 20% in total). This also applies for the technological development of the vehicles, where the average battery capacity is considered to stay below 30 kWh. Additionally, for these two scenarios, the availability of charging infrastructure in terms of location is considered to stay at a similar ratio as it is today (mainly home and public charging stations). Private charging stations (at home locations) are assumed to provide a maximum of charging power up to 11 kW on three phases, whilst charging at other locations is factored at up to 43kW AC or 50kW DC.

The Proactive and Smart Grid scenarios are expected to meet the optimistic outlook on EV market penetration (around 40% in total) and their technical development (average battery capacities up to 40 kWh). The availability of charging infrastructure is considered to be mainly focused on semi-public locations (~ 80% semi-public, private and public stations ~ 10% each). Besides the charging mode on/off for the proactive scenario, bidirectional charging of EVs is considered to be available for the smart grid business scenario.

PlanGridEV analyses the EV roll-out in 4 scenarios

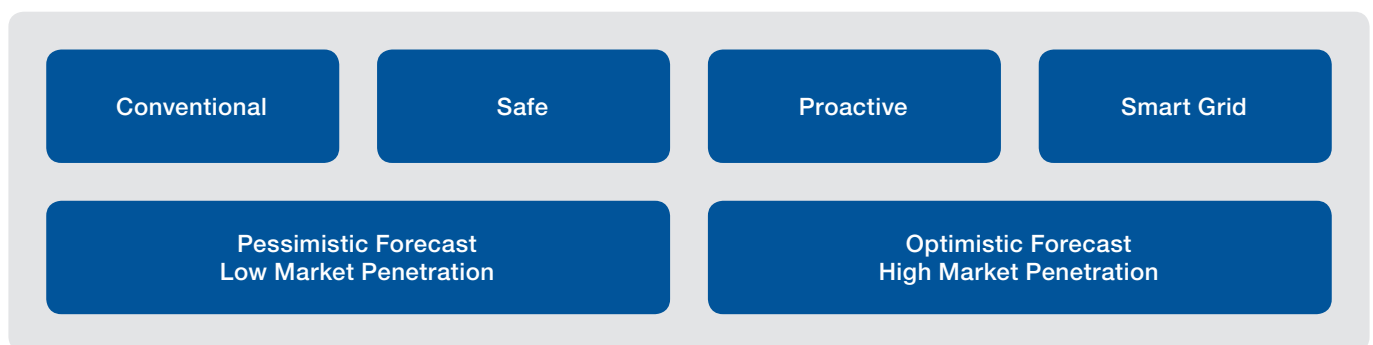

KPI report



KPI Report

Key performance indicators (KPIs) play an integral role in the definition and monitoring of critical success factors of organisations or processes. A good KPI selection also provides a valuable toolset for grid planning. KPIs act as a metric for efficiency and quality of the electricity network and can shape future planning priorities. These indicators can be directly derived from expected benefits. For example, metrics such as “number of customer interruptions” and “number of customer minutes lost” will highlight to network planners the need for network renewal or network reinforcement in a specific area. The role of a DSO has always been to ensure a high standard of quality of electricity supply at the lowest possible cost. However, this role has become more complex with the focus now including, for example, the integration of renewable generation and EVs. Greater focus is required on the wider market, including all new stakeholders. Therefore, the evolution or appearance of new KPIs will play a crucial part in ensuring that DSOs develop and explore their grids against the correct criteria for the distribution network of the future. In general, KPIs have to fulfil the following criteria:

- > **Meaningful:** KPI relates with one or several expected impacts, and therefore makes sense in terms of its contribution to achieving the programme’s overarching goals
- > **Understandable:** The KPI definition relates clearly to the expected impacts
- > **Quantifiable:** Experimental values come from field testing at an appropriate scale to be used to develop ad-hoc simulation tools that can estimate the expected impacts

One of the most important criteria for the selection of KPIs was to establish a distinction between the KPIs that would be applicable to the PlanGridEV project objectives and those with wider scope of application in the field of DSO activity. The overall vision and one of the main objectives of PlanGridEV is to design new planning rules and oper-

ational principles for the optimal integration of EVs for different network topologies and with different levels of DER penetration such as PV and wind energy. This necessitated the revision of existing KPIs at DSOs and the introduction of new indicators where appropriate.

A list of 16 key indicators, considered to be essential for PlanGridEV and its objectives, will be used further on in the project.

Project Key Performance Indicators

- > Quantified reduction of carbon-dioxide emissions
- > Hosting capacity for distributed energy resources in distribution grids
- > Share of electrical energy produced by renewable sources
- > Measured satisfaction of grid users for the “grid” services they receive
- > Duration and frequency of interruptions per customer [QoS indicator]
- > Voltage quality performance of electricity grids [QoS indicator]
- > Level of losses in distribution networks
- > Percentage utilization of electricity grid elements
- > Availability of network components and its impact on network performance
- > Actual availability of network capacity with respect to its standard value
- > Societal benefit/cost ratio of a proposed infrastructure investment
- > Overall welfare increase
- > Negative impact on consumer
- > Minimum amount of investment
- > Activation of flexibility provided by Distributed Resources (DR), Distributed Generation (DG) or other distributed controls
- > Duration of flexibility usage



Gap analysis



Gap analysis

Based on current requirements, existing grids (medium and low voltage) from participating DSOs and future scenarios, critical load scenarios which lead to violations of relevant KPIs need to be developed within the scope of PlanGridEV. In the course of the gap analysis, expected changes in the current infrastructure and the limits of DER hosting capacities need to be identified. The method for developing and simulating the different scenarios follows a state-of-the-art approach. Results for each power grid and scenario address specific KPIs. The main goal of this analysis was to assess the current EV and PV hosting capacity of existing low voltage and medium voltage grids and their limiting factors.

Following the project's advanced approach, network topology and grid user data from four LV and three MV power grids have been combined with PV production profiles and EV load profiles as input for the simulations. Different simulation scenarios have been defined to assess the hosting capacity of the different networks:

- > **ASIS (as-it-is simulation):** in this simulation scenario, the current loading of the network is investigated.
- > **PV scenario:** the hosting capacity of the network is assessed by increasing the installed capacity of PV on the network until congestion occurs.
- > **PV+EV scenario:** starting with the installed PV capacity from the PV simulation, EV is connected to the grid until network congestion occurs.
- > **Extra PV scenario:** the potential extra PV capacity which could be connected due to the presence of EV is investigated.

The primary goal of the gap analysis was to estimate the hosting capacity of various LV and MV networks and identify the limiting factors restricting the hosting capacity. Therefore, multiple scenarios have been investigated.

Starting from the current loading situation, PV has been connected to the grid until the grid loading became critical. Departing from this maximum amount of connected PV, the EV hosting capacity has been assessed.

For the LV networks, it is shown that the hosting capacity of rural networks is generally lower compared to urban networks. Concerning factors limiting the hosting capacity, the results show that critical voltages can be expected for rural networks. For urban networks, critical transformer loading and critical line loading are limiting the hosting capacity.

This suggests that it could be interesting for a network operator to monitor the voltage at rural networks and to monitor transformer and line loading at urban networks to estimate the capacity left for PV or EV connection. For this purpose, some KPIs have been investigated, which give information about the loading condition of grid elements and the use of the available voltage band. More LV networks have to be investigated to search for such a correlation. The effect of the connection of PV and EV on the losses has been investigated. For networks with a smaller PV hosting capacity, the connection of PV results in a decrease of the losses (10 % to 36 %). In those cases, PV production is consumed locally, reducing overall power flows in the network. For networks with a high PV hosting capacity, the PV production can exceed local consumption and possibly result in higher losses compared to the situation without PV.

For LV networks, the connection of EV results in an increase of the losses. This increase varies significantly from 5 % to 180 % compared to the case without EV. On the other hand, the connection of EV allows for additional PV to be connected. Especially when critical voltages were limiting the hosting capacity, the hosting capacity of PV was increased significantly (> 50 %).

The results for the MV networks are comparable to the results for the LV networks. As was the case for LV networks, the calculated hosting capacities for MV networks differ significantly. However, it is interesting to notice that the HV/MV transformer does not limit the PV and EV hosting capacity in any MV network. For rural networks, critical voltages limit the hosting capacity. In urban networks, critical line loading poses limits to the hosting capacity.

For MV networks, a clearer correlation between the value of the calculated KPIs and the hosting capacity was found. An assessment of the used voltage band and the line loading provide useful information about which of the two factors limit the hosting capacity.

The analysis of the effect of a high amount of PV confirms the results from the LV networks: the losses of networks with a smaller amount of PV connected decrease (15 %) whereas networks with a high hosting capacity experience an increase (20 % to 35 %) in losses at full PV hosting capacity.

Consistent with the results of from the low voltage networks, the connection of EV increases the hosting capacity for PV more if the PV hosting capacity is limited only by overvoltage. A 15 % increase has been calculated.

Limiting Factors for PV hosting and EV hosting

Network	Limiting factor for PV hosting capacity	Limiting factor for EV hosting capacity
LV Rural	overvoltage	undervoltage
LV Urban	TFO loading/line loading	TFO loading/undervoltage
MV Rural	line loading/overvoltage	line loading/undervoltage/overvoltage
MV Urban	line loading	line loading



State-of-the-art methods



A complete review of the state-of-the-art methods applied to distribution planning has been compiled. It is a key element for the development of new innovative methods within PlanGridEV as it provides a reference regarding existing methods and tools.

The experience of the Distribution System Operator (DSO) members on the PlanGridEV consortium and their knowledge about their own grids and planning rules were used. This was complemented by the additional knowledge of research and power system consulting partners who have explored in depth the classical distribution planning problem and the efforts made to date to improve and redesign distribution planning tools to meet present and future needs.

Traditionally, the distribution planning problem has been solved in a step-by-step process that includes some simplifications such as considering consumers as passive elements and routinely setting parameters for the most severe operation scenario. The main goals are to meet the highest peak load demand within the required reliability standards and for the lowest possible cost.

The first distribution planning methodologies followed a deterministic process, since the existing computational power and availability was limited. In time, parts of the

process were automatised, but the main rationale remained unchanged. Recently, increasing levels of Distributed Generation (DG) plus the expected rollout of Electric Vehicles (EVs) have been introducing uncertainties. The worst case scenario that should be evaluated is no longer necessarily peak load, as off-peak conditions could cause voltage and reactive power problems in the presence of DG. At the same time, there is a greater concern in developing longer term plans with the prospect of achieving better overall solutions.

Advances in smart grids and Demand Side Management (DSM) have been made as a response to these challenges. Hence, planning assumptions must be revised to effectively integrate and consider the potential benefits of these concepts. Major advances have been made in terms of new operation scenarios including DG and/or DSM, but their integration into planning lags behind. The new distribution paradigm of smart grids with active participation of Distributed Energy Resources (DER) and load in network operation deeply relies on an adequate communication infrastructure. Thus, the challenges of communication must be understood and incorporated into the planning problem as alternatives to conventional reinforcements.

Capabilities of existing planning tools

- **We involved seven European DSOs**
- **Eleven state-of-the-art planning tools were analysed regarding**
 - > Operational planning
 - > Investment planning
 - > Operational & investment
- **Most of them follow the classical planning approach**
 - > Single loading scenarios
 - > Focus on peak load (or max. distributed generation)
 - > Load flow simulations
- **At the end PlanGridEV sees the following as potential new features for grid planning**
 - > Storage
 - > Uncertainties (of DER)
 - > Demand side management
 - > EV integration
 - > Alternative investments

Future distribution planning tools should include better representations of the uncertainties posed by DER. DER units based on intermittent energy sources such as wind and solar require complex modelling for grid planning, where energy availability also needs to be represented. Besides using measured data from reference DERs for grid planning, methods for generating artificial data based on statistical methods are also applicable.

There are also many models used to represent the charging flexibility of EV fleets. Whereas the state of the art provides a good starting point, existing models will need to be adapted to the specific requirement of the planning tool to be developed in PlanGridEV.

Future grid planning process

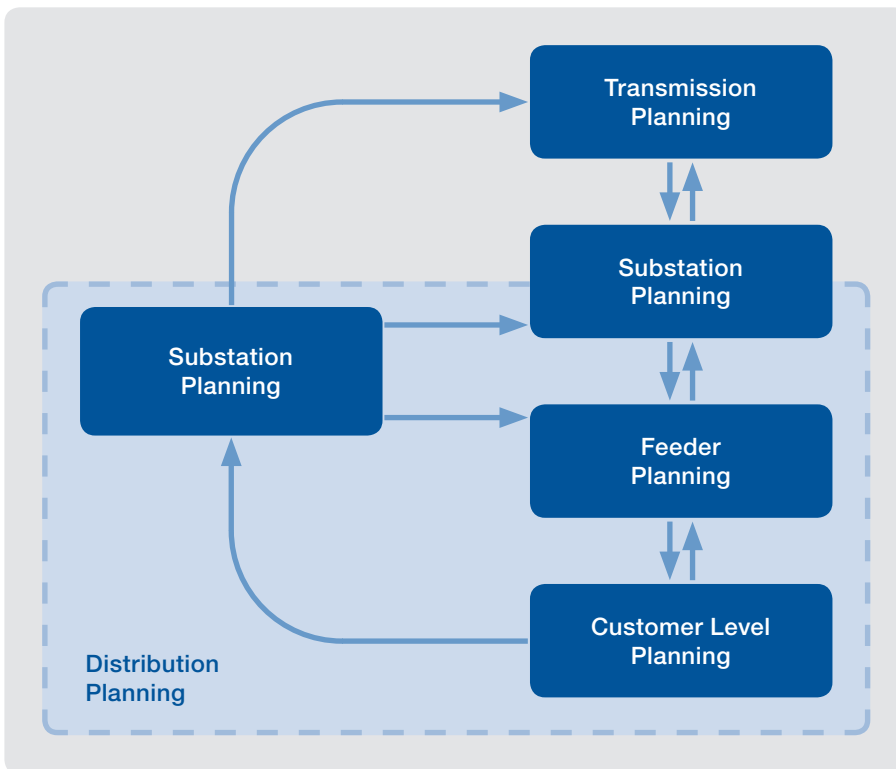

The classical planning approach has to be adapted towards a new approach that takes into account the new realities in distribution systems. The increasing penetration of DG should be considered, as well as other developments such as electric vehicles, demand side management and other smart grid technologies



EV grid integration business scenarios



Business scenarios for the integration of electric vehicles (EV) into Low Voltage (LV) and Medium Voltage (MV) electricity grids have been defined. These business scenarios are an important input to be considered throughout the project.

When aiming at integrating electric vehicles in distribution grids, the distribution system operator (DSO) may opt for either reinforcing the grid or for managing the load (or a combination of both strategies). A number of business scenarios have been selected for the analysis.

- > **Conventional**, where no load management is considered and EV integration must be faced via grid reinforcements and, generally, by investing in widening the existing hosting capacity.
- > **Safe**, adding soft fleet-focused load management to the conventional grid reinforcements, possibly reducing the effort in widening the hosting capacity only through copper investments.
- > **Proactive** load management, dealing with massive EV penetration and, thus, minimising the need for grid reinforcements.
- > **Smart grid**, with a granular control of EVs' load management that allows for optimisation of hosting capacity, additionally considering the local connection of distributed energy resources (DER) that can benefit from EV penetration, via a positive feedback loop.

General electric mobility business framework for PlanGridEV

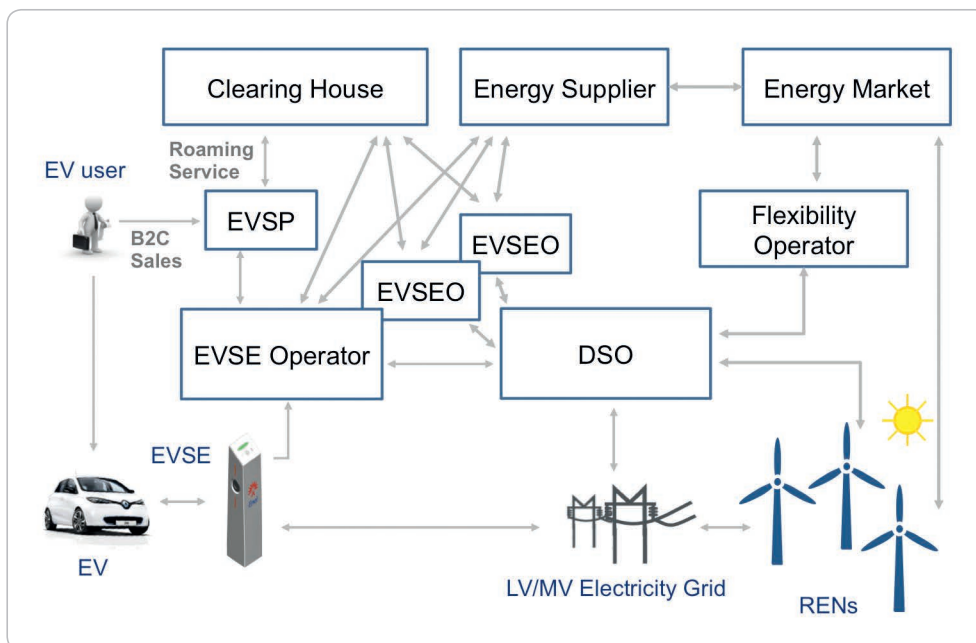

Taking all the actors, restrictions and demands into account leads to very complex and challenging models which have to be solved in real time to provide the desired services. A major challenge here is the number of actors interacting even in simple use cases.

Summary of main characteristics of the different scenarios

	Conventional	Safe	Proactive	Smart grid
Charge management	No	Soft, fleet-focused	Massive	Massive, local
Type of charge management	None	On/off	On/off	Charge modulation
Expected grid reinforcements:				
– Non EV-related	Yes	Yes	Minimal	No
– EV-related	Yes	Minimal	No	No
Energy flow in EVs that are used to provide services	None	Grid > EV	Grid > EV	Grid < > EV
Provider of the service	None	EVSE Operator (fleet manager)	EVSE Operator/EVSP	EVSP
Remuneration scheme	None	ToU	Regulated contract	Competitive market
Type of power flow control for¹:				
– Emergency constraint mgt.	Centralised	Centralised	Centralised	Centralised
– Forecasted constraint mgt.	None	Centralised	Decentralised	Decentralised
– Real-time constraint mgt.	None	None	None	Decentralised
– Ancillary services for the TSO	None	None	None	Decentralised
– Energy trade	None	None	None	Decentralised
– DER integration	None	None	None	Decentralised

¹Centralised control means that the DSO is controlling the charge, while decentralised means that either the Electric Vehicle Supply Equipment (EVSE) Operator or the electric vehicle service provider (EVSP) are taking control.

Each of these scenarios will be strongly influenced by the regulatory conditions existing in each country. Regulation may positively or negatively affect EV deployment in many ways. If regulation is not flexible enough, or the requirements to perform some of the roles are too demanding, business models that can help the electricity system as a whole may never happen. On the contrary, too loose requirements may result in risk for system security. A detailed analysis must be carried out to evaluate the regulatory change and updates needed in order for an envisioned EV grid integration scenario to take place. All affected parties should be allowed to implement their business activities in a profitable way.

Requirements should be coherent throughout Europe to allow for interoperability. However, in order to bring solutions to the market as soon as possible, it might be advisable to propose different implementation phases with

different targets and requirement levels according to the real evolution of the EV market.

In addition to regulatory issues, the actual impact of the scenarios will depend on the existing conditions of distribution grids. A lightweight economic analysis has been performed to give an idea of the economic impact of the different scenarios in distribution grids. Due to the lack of disaggregated data, a country-wide estimation of the impact at the distribution level has been conducted. This may provide only a partial view of the potential of the scenarios, particularly in the case of the smart grid scenario. Moreover, the cost of launching each scenario for the DSO must be assessed in more detail to get a better estimate of their potential impacts. Being one of the countries with the most ambitious EVSE installation targets and due to the availability of data, Spain has been used as an example for the assessment of the economic impact.



D2.2

Technical requirements for tools/ methods for smart grid integration of EVs



Tools and methods have been designed according to the specific purposes of each of the four PlanGridEV test beds (Italy, Portugal, Ireland and Germany). Therefore the requirements are derived through test-bed overviews and a selection of products/services for the advanced integration of EVs into the LV/MV electricity grid. For each of them the different stakeholders have been defined and it has been described how they should interact and what technology enhancements are needed to implement the test bed.

Portugal's test bed (run by EDP) matches the Conventional Scenario. Some minor adjustments were made against the Conventional Scenario, especially in order to predict the possibility of electricity grid investments where EDP's proof of concept provided through this project cannot be applied.

In the **Irish test bed** (run by ESB) there were four different configurations:

- > No EVs connected.
- > Restricted EV charging. Charging allowed to charge between 11 pm and 7 am only.
- > Staggered EV charging. Charging permitted for 2 of every 3 hours (ensuring maximum of two cars charging at any one time).
- > Unrestricted EV charging. Charging permitted at all times.

These scenarios give a good representation of the effects of EV charging and the possible benefits of future smart grid technologies applied to EVs. It is planned that this trial will lead to a recommendation for future smart grid implementation, especially related to the planning of electricity grid in order to sustain an increasing EV penetration. This would move ESB to the adoption of a more advanced scenario such as Proactive or Smart Grid scenarios defined by PlanGrid EV.

Germany's test bed (run by RWE) and **Italy's test bed** (run by Enel) match the Smart Grid Scenario, but without a competitive market interaction and with unidirectional energy flow. For the Enel test bed, by taking account the status of the LV/MV electricity grid and the forecast of availability of renewable production, the EV recharging process is to be modulated in order to create value for all stakeholders involved during the process (customer, DSO, EVSE Operator, DER Operator). This is matching the services described as "Planned Demand Response: Enhancement of Renewable Energy (RENs) integration". For Germany's test bed, the same case is being applied but at local level, triggering enhancement of local RENs integration. In this case Germany's test bed can be understood as a proof of concept for the implementation of a "Quasi-Real Time Demand Response: Enhancement of RENs integration service". In fact, within Germany's test bed, the deployment of controllable equipment and appliances at household level, including EVs, allows an optimum integration of local RENs.

Framework architecture of electric mobility and embedded IT interfaces (IF 1... 8)

For a basic charging service EV and EVSE need to be physically connected in conductive charging according to ISO/IEC 61851 (IF 1, arrow between EV and EVSE). This is as a consequence of the charging process authorisation, which happens by validating the B2C relationship between the EV user and their preferred EVSP (IF 5, arrow between EV user and EVSP). Each EVSP has to guarantee access of their EV users in a set of charging stations (EVSEs) to which the EVSP has established a B2B relationship, either by bilateral contracts (IF 4) or by a marketplace-based model, according to the demonstrations run within Green eMotion FP7 project.

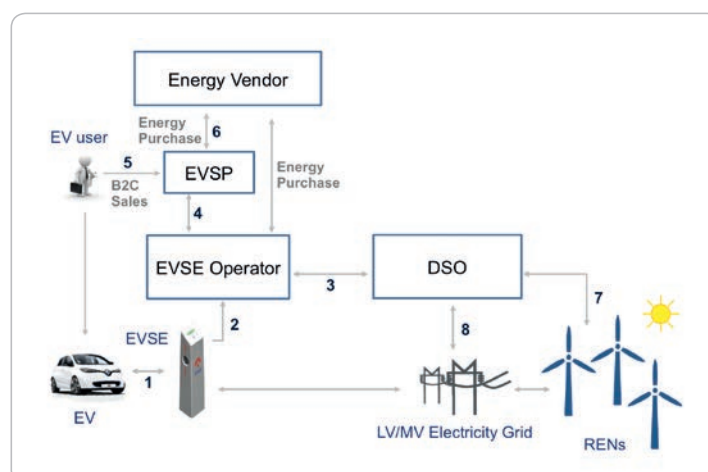

Economic tools for smart-grids' integration of EVs



A business case analysis of a class of services/products marketed within the Smart Grids scenarios has been set up to analyse hypotheses for the economic investments to sustain the vision, ecosystem and regulatory framework needed for the selected scenario. It makes references to the gap analysis against the current situation as required.

Tools for assessing the integration of the EVs into smart grids have to take into account: input directly connected to the supply of the vehicle (systems of energy production and distribution); input related to operating conditions (efficiency, emissions in the use case, etc.) and input regarding the context of the car's use (air quality, vehicular traffic flows, regulations, weather conditions, etc.). Moreover, in the evaluation of the integration of EVs into smart grids it is important take into account the ability of the smart grid and the EVs to communicate with all the necessary parties.

An important characteristic of smart grids is the opportunity of bi-directional energy flow. In the automotive field, this means the possibility of a Vehicle to Grid (V2G) system.

The sustainability of an energy system may be assessed on the basis of the five pillars of energy sustainability (efficiency in energy conversion, distribution, use, lowering of environmental impact; increasing of energy accessibility, tailor making of energy systems on local social-economic-environmental conditions).

Deployment of smart charging service

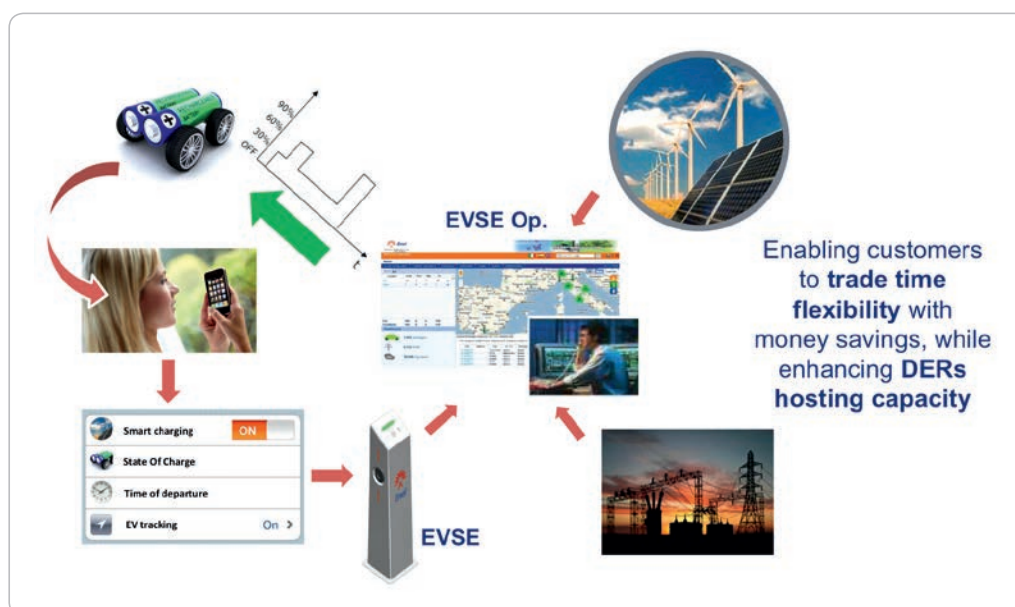

The EVSE operator builds the link between renewable energy sources, grid and customer. While ISO15118 is not yet fully in place the customer interacts with the system with his smart phone.



Network Architecture Model



The developed Network Architecture Model contributes to the overall design process of the PlanGridEV systems, planning tool evaluation and communication architecture. It provides a state-of-the-art analysis of communication protocols and systems related to the PlanGridEV approach in order to provide a comprehensive communication reference architecture that is capable of meeting the projects requirements. The main objective is to select the most promising protocols and networks via which exchange information among the different systems and stakeholders, considering the present state of agreement and the potential to fulfil needs such as speed, reliability and cost. The selected architectures and protocols will constitute the ICT section to be included in the different scenarios when planning the smart grid in short, medium and long term.

It is elaborated that the huge disruption to stakeholders' businesses could be minimised by summarising comparable Back-End-to-Back-End communication interfaces to regular ICT solutions. For this purpose, a subset of technical units has been identified and mapped to each introduced stakeholder within PlanGridEV. We defined a reference architecture design considering relevant PlanGridEV requirements and providing several ICT networking topologies for Front-End, as well as for Back-End communication. Therefore, different network topologies are exemplified and motivated, wherein requirements of below listed charging locations are considered:

- > **Public charging**
- > **Semi-public/private charging**
- > **Private charging**

The reference architecture design provides the basis for a state-of-the-art analysis for transmission technologies and application protocols on all relevant ICT interfaces. Feasible ICT transmission technologies, as well as application protocols, are discussed in detail. Especially for Back-End communication, cellular mobile radio systems are feasible and cost efficient solutions. Wireless Technologies, like GSM, UMTS, as well as LTE, offer cost-efficient solutions for new communication infrastructures. This is due to the large reduction in installation costs for cabling, as only base stations have to be connected to an underlying IP network. Since installation costs for wired standards are higher compared to wireless technologies, the integration of existing infrastructures in PlanGridEV approaches is widely preferred. In terms of ICT application protocols, PlanGridEV solutions should depend on standardised communication protocols, in order to ensure reliable and interoperable interaction between all entities of the system. In this context, PlanGridEV DSOs' view is intensively incorporated, by analysing current implementations of interfaces and/or services for relevant ICT interfaces, as well as future visions. This is extended to a procedure for a necessary requirement definition for desired use cases and provides the opportunity to evaluate suitable assessment and technology recommendations for a pre-defined energy grid use case.

Categorising different wireless network technologies in terms of their typical coverage and data rate

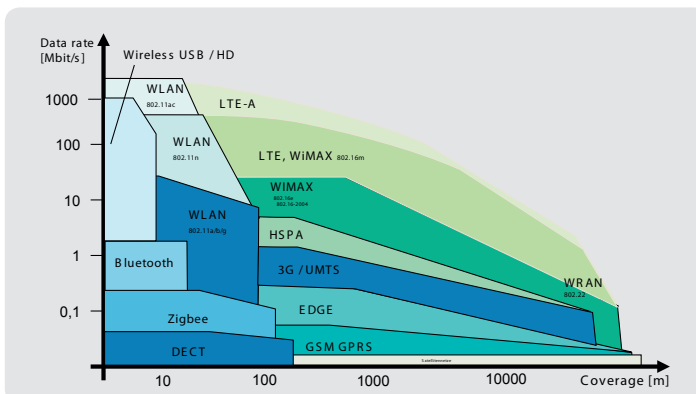

The figure serves to illustrate the positioning of wireless technologies compared to each other. It represents typical data rates and coverage. Under ideal conditions, greater coverage and higher data rates are possible, under bad conditions data rates and coverage could reach significantly lower values.

Specification of energy grid/ Functional and service architecture



The general elements that allow high level description of smart grid system architectures have been defined. On this basis use cases and scenarios considering the technical and business model perspectives have been analysed.

Based on the Smart Grid Model Architecture (SGAM) approach, the following elements have been identified and proposed for use case and scenario definition:

- > **Services**, which represent the core of business models
- > **Functions** that enable services development.
- > **Information** describing the most typical data exchanged in order to carry out functions and services. This is one of key aspects of the study.
- > **Communication technologies** addressing the most physical aspects of information exchange.
- > **Components**, which consist in devices and systems but also in parties that communicate with each other and carry out the objectives set by functions.
- > **Market models** that define the market structure influenced by regulatory and business factors.

With this framework in mind, three **business cases** leading to three network scenarios have been defined:

- > **Proactive/Smart Grid:** it considers Advance Metering Infrastructure (AMI) and Distribution Automation (DA) technologies deployment, together with EV related smart charging for network operation. Hourly prices based on dynamic network fees are proposed during normal operation of the network, while critical peak pricing (CPP) strategies and generation premiums are used to leverage customers' flexibility for ancillary service provision, supporting unexpected conditions in the network.

The figure gives an overview about the complexity of even simple cases like normal operation. Economic relationships and necessary communication links together with appropriate protocols are visualized.

- > **Safe/proactive:** it is based on the extensive implementation of 'time of use' tariffs and on the basic management of EV charging processes during network contingency situations.
- > **Conventional (business as usual):** it assumes that current network operation and planning procedures remain unchanged in the future.

Business cases have been described using standardised formats and, from them, network scenarios have been derived. Simplified scenarios are defined, considering the most relevant characteristics that will permit to perform the economic assessment, including concepts such as maximum and minimum demand in the system, electricity consumption, infrastructure capacity, distribution losses, DER hosting capacity and generation, reliability and CO₂ emissions.

An exemplary base case electricity network scenario has been built in order to prove a top-down approach methodology via which complete distribution systems can be analysed. Three different evolution options, in accordance with the business cases presented before, have been analysed, leading to the Conventional/Business as Usual (BaU), Safe/Proactive and Proactive/Smart Grid network scenarios.

Proactive/Smart Grid business model. Normal operation

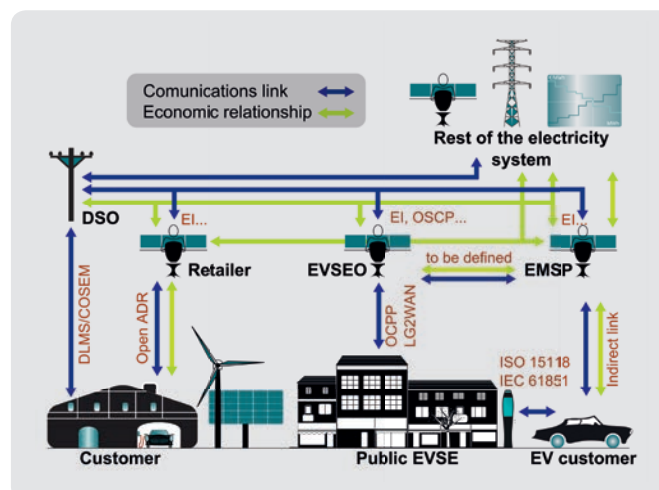

New ICT developments and services for EV integration in electricity distribution networks



The evolution of distribution networks towards smart grids pursues lower environmental impact through optimised processes for higher efficiency and the deployment of cleaner energy production technologies. To achieve this, the system must transit from a passive to an active network, requiring remote and automated control systems and the integration of distributed energy resources in operation processes. In this framework, the involvement of ICT systems is critical to allow high penetration of EVs in the system through network services provision.

Four categories of smart grid strategies have been considered for network planning and ICTs are present in all of them:

- > **Distribution Automation (DA):** this deals with network devices and strategies linked to network operation, e.g. network reconfiguration and topologies, voltage control strategies, network monitoring, etc.
- > **Advanced Metering Infrastructure (AMI) and automatic meter reading (AMR):** smart meter related features and technologies.
- > **Distributed Energy Resources (DER) integration:** distributed generation, storage and demand management resources (including EVs) for distribution network operation.
- > **Customer empowering:** devices and strategies that can induce customers to change their energy consumption habits.

During the smart grid project planning phase, the operation strategies maximising technical features and minimising investments and operation and management (O&M) costs have to be selected. The minimum number of interventions providing the expected results has to be considered, e.g. number of feeders refurbished with remotely controlled switches or the number of automated secondary substations. Therefore, a **smart grid project assessment** must be performed, both economically and technically, to compare the results provided by different planning strategies, in order to choose the best solution among them.

DER system involvement in network operation processes is one of the main tools for flexibility enhancement in smart grids and the principal scope of this study. The services that could most suitably be provided by EVs and other DER systems to the network have been analysed through use case descriptions:

- > Frequency regulation.
- > Load balancing.
- > Voltage regulation/reactive power provision.
- > Peak shaving.
- > Load profile flattening.
- > RES integration.

A general **ICT network architecture** is proposed considering all services listed above. The architecture is comprehensive, so it can be taken as general reference for use case development. As a consequence, it has to be particularised for each specific deployment, considering the mapping between stakeholders and roles in the regulatory framework, the service requirements and the market and business model characteristics. The proposed architecture is shown in the next schematic.

Most utilities use currently more than one means of communication, depending on the functionality and service they need to cover through network operation. This will still be the case in smart grid environments, even if the complexity of ICT systems will increase significantly. DSOs will require a distribution automation network, an AMI network and a DER control network, but these can be shared to some extent. The following solution is proposed:

- > **One common ICT infrastructure for AMI, non-critical distribution automation, DER control and customer empowerment:** the final solution should be scalable, built upon standard solutions when available, hierarchical according to the aforementioned architecture and considering security and reliability aspects from the design phase. Public networks could be used for less critical information exchange and service level agreement options could be chosen for communications requiring intermediate resiliency.

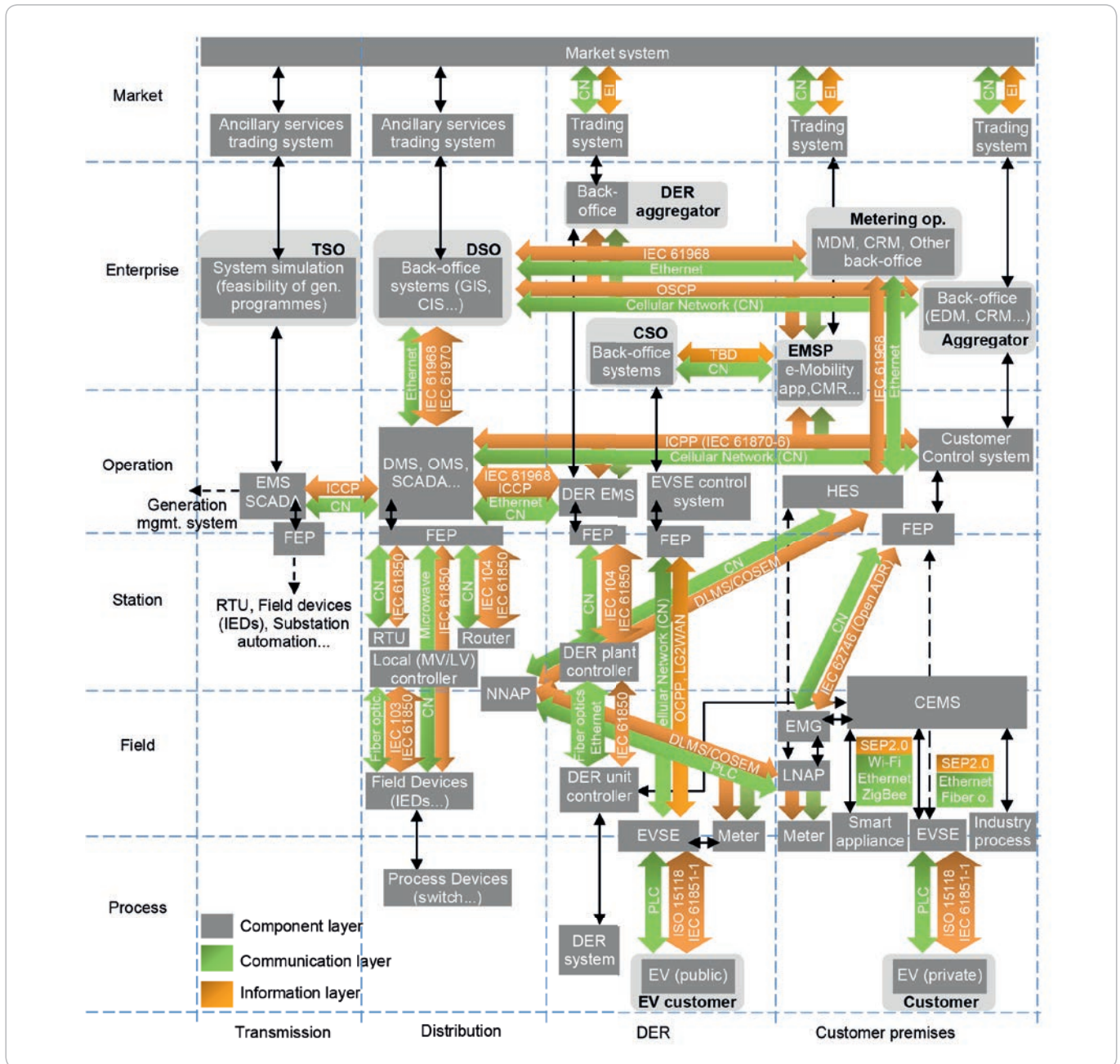

> **Critical distribution automation ICT infrastructure:**
 These networks are normally local area networks in charge of connecting control systems with intelligent field devices through fast and reliable technologies such as fiber optics. Security risks should be carefully assessed and managed, and reliability improvement strategies should be deployed to minimise disturbances associated to network operation. Private networks are recommended.

one proposed in this document. The use of ICTs in the electrical system is already a fact, mainly in the transmission system but also at energy distribution level. It is expected that this dependency will increase.

PGEV project **test beds** are a step towards future smart grids and, as consequence, their architectures fit to the

Technical solutions, market aspects and regulatory frameworks are critical to permit the deployment of ICT-based strategies. This deployment should be based on the optimum solution implementation, always targeting sustainability. Therefore, apart from technical and cost aspects, socio-economic impacts should also be taken into account in the global assessment of solutions.



D4.1

Definition of the optimisation problem and tools specifications



A future grid planning tool must address the new challenges of distribution, mainly dealing with the increased levels of uncertainty of the system, new trends in observability and controllability of the network.

The increased levels of penetration of Distributed Generation (DG) accompanied by perspectives of increased load, for instance, with the integration of heat pumps and Electric Vehicles (EVs) are introducing major uncertainties to the planning process. Typical planning rules explore the worst case scenarios, which in the context of the increased uncertainty may lead to overinvestment.

Today's vision for distribution grids introduces greater levels of observability and controllability into distribution, implying a transition from passive grids to active grids.

So-called smart grids bring benefits that are currently not considered by distribution planning tools. Such a fact does not allow the clear identification and understanding of the real benefits of having a number of different control options, such as demand response, EV charging control or DG modulation. All these options rely on proper ICT infrastructures, for which investment must be made and should be foreseen, having an impact on expansion plans.

Due to these changes, new stakeholders are rising as conceivable investors in distribution planning, more specifically in the ICT assets for demand response activation. New business models that are being developed must be studied. The prototype tool developed within PlanGridEV is able to test and capture the different dynamics that these new models bring for expansion planning.

Building blocks of a future distribution planning tool

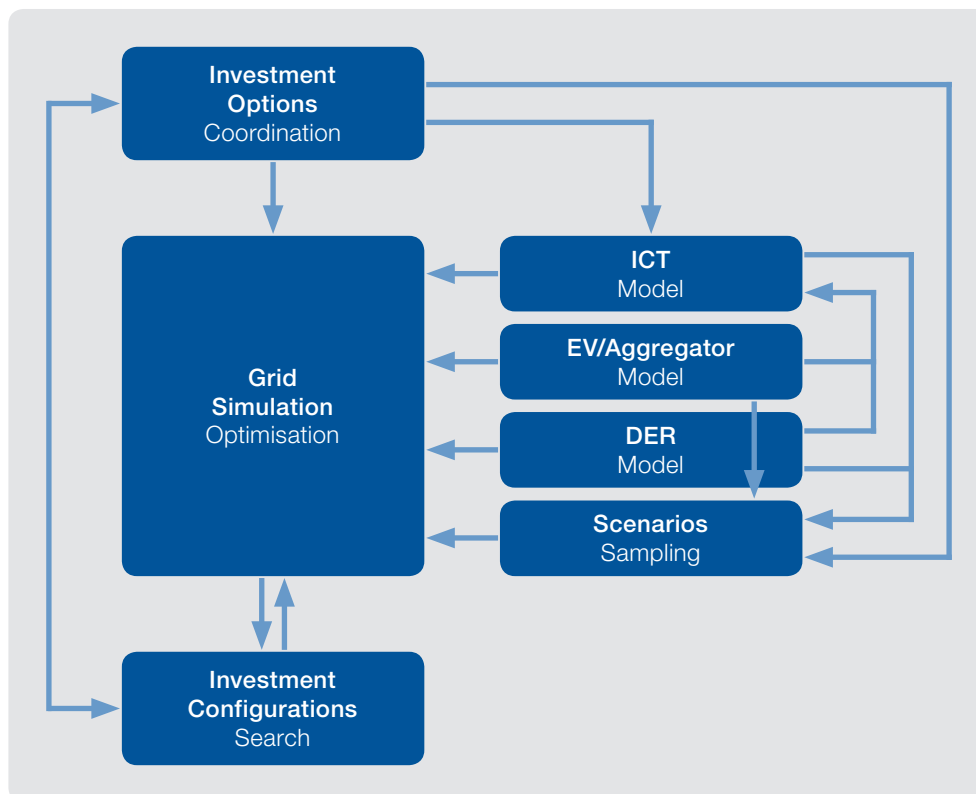

The planning tool must address the new challenges of distribution, mainly dealing with increased levels of uncertainty of the system, new trends in observability and controllability of the network.

New methods to maximise integration of EVs and DER in distribution grids



Methods for optimisation under uncertainty, for storage modelling and for the statistical behaviour of EVs and DER

The first implementation for the development of a distribution planning prototype tool has been executed and covers the main constituents of the new planning tool. For each task the mathematical models which are defined to tackle the different problems are presented.

The method aims to describe the load profiles and flexibility constraints associated with the EV charging process, taking as input individual EV mobility profiles and consumed energy while commuting. It aggregates these data in clusters and uses it to derive the profiles and constraints for each of the clusters. This way load profiles of charging EVs are computed if there is no type of active charging management. Additionally power and energy constraints are determined for EV charging in active management scenarios.

Concerning the statistical generation of EV mobility profiles, a method has been developed capable of addressing different environments in different countries, based on available mobility statistics. It generates a population of EVs within a given area, draws a travel chain and estimates the distance driven during the multiple travel segments of each EV.

For the DER statistical behaviour methods, three methods have been developed, for wind, PV and CHP profile sampling. A common structure has been proposed through the definition of a modular DER modelling methodology, which allows the establishment of a process that starts with the weather/external data collection and ends with the generation of statistical profiles based on the gathered inputs. In all cases the curves that are drawn are statistically valid, preserving the input data characteristics, but allowing multiple generation profiles to be drawn.

Another key aspect addressed is the development of investment planning methods based on multi-objective optimisation. A hybrid approach has been implemented for tackling the problem of investment planning.

The incorporation of ICT and information exchange within the prototype tool has been specified. A solid methodology for addressing the impacts of ICT in distribution network planning is presented, including benefits and costs. The proposed methodology uses ICT evaluations to define control scenarios and constraints for the simulation of distribution networks. It allows assessing ICT effectiveness, while maintaining a rather low computational burden. The ICT model analysis can deliver technical costs, such as:

- > data rate
- > coverage
- > response and processing times
- > availability, etc.

Additionally, it allows a comparison between several Smart Grid Protocol Parameterisations and directly leads to the most promising protocols and technologies by a simple ranking of solutions according to its weighting-points.

It is worth mentioning that the interactions between the individual modules have also been addressed.

Aggregation of individual EV travel by destination

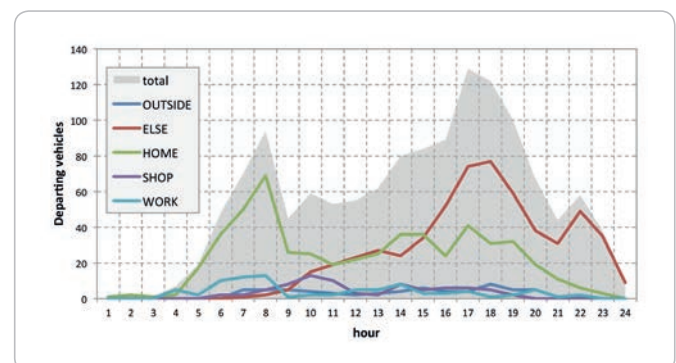

A method for generating statistical EV mobility profiles has been developed and is capable of addressing different environments in different countries, based on available mobility statistics.



Prototype tool for optimising existing assets and grid planning using controllable loads



The developed prototype tool builds upon the analysis, models and methods developed in PlanGridEV.

An AC Optimal Power Flow (OPF) methodology is developed as part of the prototype tool to optimise power system related operational choices. Next to unit characteristics, OPF problems take into account the physical behaviour of the grid. Technical information is required to be able to solve such OPF problems, for instance, information on how the grid is structured, which technologies are used and, what the operational limits are, etc. The manual therefore discusses which models are included and which parameters are required to define a valid case study. This is needed to capitalize on the tool in context, to support grid planning processes. The aim is to be able to support and validate grid investment decisions in controllability.

The OPF simulation core tackles both low voltage and medium voltage distribution grid case studies. This means that mathematical methods used are valid, robust, and have sufficient numerical performance for the simulation of radial networks of varying voltage levels, with varying combinations of underground cables and overhead lines, and for varying reactance-to-resistance ratios. The calculation core performs balanced power flow analysis.

Furthermore, the OPF methodology includes support of multi period simulation (simulation of multiple time steps at once). In the unit models (e. g. EVs) a number of dynamics are taken into account, such as storage processes over time.

A library of unit models is provided with the tool, including curtailable generators, sheddable loads, PV system models and EVs (including vehicle-to-grid). For DER and EV, the tool includes methods to generate representative behaviour, to simplify the setup of case studies by the user.

Due to the large-scale and multi period nature of the simulation, the tool returns a significant amount of numerical results. It is rather time-consuming to explore such results using conventional spreadsheet software. Therefore, to streamline the interpretation and analysis of the results, next to the numerical results, the tool returns a number of figures, all adhering to a common visualisation approach.

PlanGridEV file uploader

PlanGridEV project partners have access to the tool through a dedicated website. The user uploads a complete template and receives the results by email once calculated.

Usage of statistical data in the planning tool

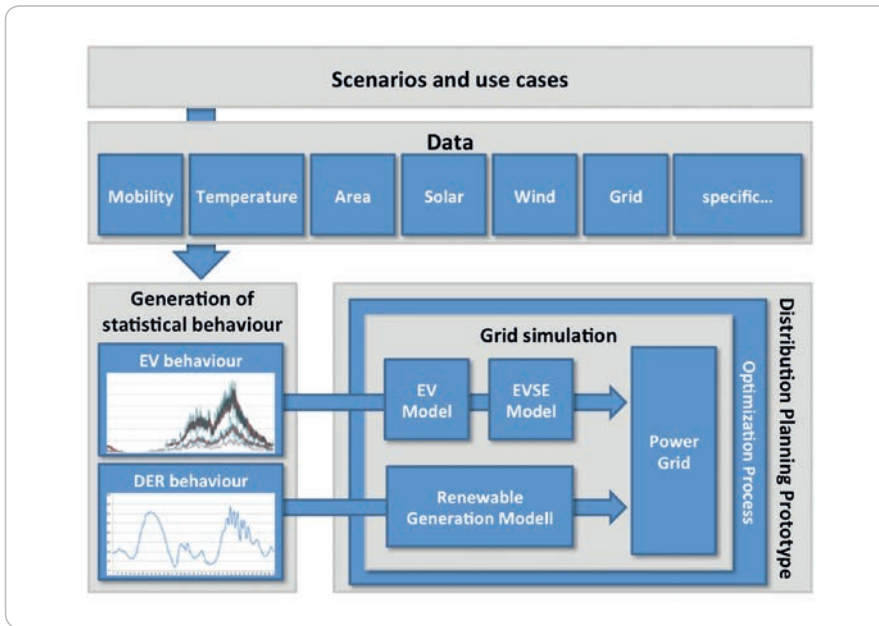

To be able to simulate the grid for planning purposes based on scenarios and use cases the necessary data has been gathered and summarised in statistical models for EV behaviour and DER behaviour. Based on this generic statistical data on behaviour EV, EVSE and Renewable Generation models can be used to simulate real grid situations as the bases for the following planning process.

Modelling of EV behaviour

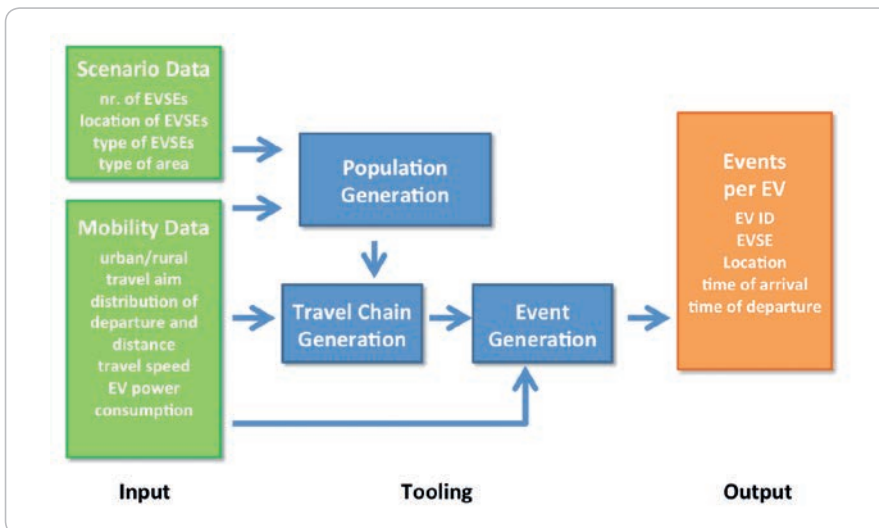

To model EVs, especially the fact that they move and get connected to different grid connection points throughout the simulation has to be taken into account. Based on an assumed population of cars with type specific parameters e.g. charging capabilities and battery size and a movement scheme derived from customers' needs in certain areas, an event list for every EV is generated to configure the grid model for the calculation.

Modelling distributed renewable generation

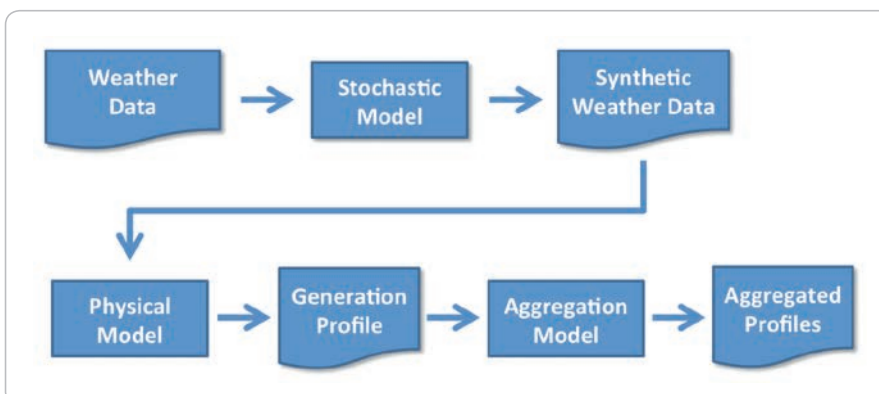

To provide the calculation model with appropriate data for the renewable generation derived from weather models and physical models of PV and wind generators an aggregated generation model for each grid connection point is generated. The resulting generation profiles are used to describe the renewable generation in the prototype tool.



ICT Model of planning tool



Choice of ICT infrastructures and technologies in smart grid planning

PlanGridEV proposes an approach for a comprehensive modelling approach for a techno-economic evaluation of ICT infrastructures for future smart grids. Implementing overarching ICT provides control and monitoring capabilities compared to traditional grids, despite remarkable alteration towards distributed generation and storage systems. The choice of ICT technology and infrastructure in smart grids involves numerous different solutions for a wide range of applications, beginning with straightforward Automated Meter Readings (AMR) up to extensive Demand Side Management (DSM). Related communication is mainly based on Machine-to-Machine (M2M) communication, covering several stages of automated communication processes, distinguishing between a few technical units located in Local Area Networks (LANs) and up to thousands or even millions of devices located in Wide Area Network (WANs).

The main objective of efficient planning is to select overall, most promising communication technologies and infrastructures where information can be exchanged among the different systems and stakeholders, considering the

present state of agreement and the potential to fulfil communication requirements such as speed, reliability or costs. For this purpose, our proposed ICT Model consists of three different functionalities: Smart Grid Traffic Modelling consisting of

- > traffic and a device/connection point modelling,
- > Network Dimensioning and
- > Cost Modeling based on an economic analysis.

Hereby, the ICT Model considers the most appealing candidates of transmission technology solutions with regard to their suitability for future grid applications:

- > Dedicated Long-Term-Evolution (LTE) network.
- > Combination of dedicated LTE and wired Broadband Power Line Communication (PLC) networks.
- > Dedicated Fibre networks.
- > Tariff network – using tariff networks includes the use of public network structures (e.g. GPRS, UMTS, LTE). In contrast to dedicated networks, public networks should result in lower infrastructure costs.
- > Mixed region – using mixed region networks considers capabilities to design different transmission technology solutions for different energy network areas (e.g., urban fibre and suburban, rural LTE networks).

Charging EV at public charge pole



In order to apply modern smart control schemes to charging vehicles there has to be an online connection from the EVSE Operator to the charge pole (EVSE). Since public charge poles are at the curb side and away from easily available ICT connections, public wireless infrastructures have to be analysed to ascertain if they can provide the necessary reliability for system control.

The Smart Grid Traffic Modelling differentiates between use case groups and connection points, which are physical communication devices divided into three categories, private, public and grid. These devices are then categorised in four use case groups: Automated Meter Reading, Distributed Generation and Storage, Distribution Automation and Demand Response. These use cases linked to a definition of traffic requirements, which are packet size, arrival rate, required latency and service priorities. With this model, the minimum data rate requirement and monthly data volume per connection point can be used to calculate the total data rate requirement and total data volume of the corresponding scenario.

The Network Dimensioning part uses requirements calculated in the Smart Grid Traffic Model and combines them with a database of communication technologies and their respective properties regarding, for example, data rate

and latency. Considered technologies are basically dedicated LTE infrastructure, dedicated fibre infrastructure, PLC distribution network with LTE wide area network and mixed network solutions (e.g. urban fibre + suburban and rural LTE networks).

Results of the technological dimensioning serve as input for the cost modelling, examining the Total Cost of Ownership (TCO), the net present value and the cost per device per month for the different network approaches made beforehand. Cost components are exposed and divided into capital expenditures (CAPEX) and operating expenditures (OPEX), in the first tier, and network respectively task context, in the second tier.

The figures below serves to illustrate an overview of relevant ICT Model Input and operation, as well as output parameter.

Structure Overview of ICT Model for Distribution Network Planning

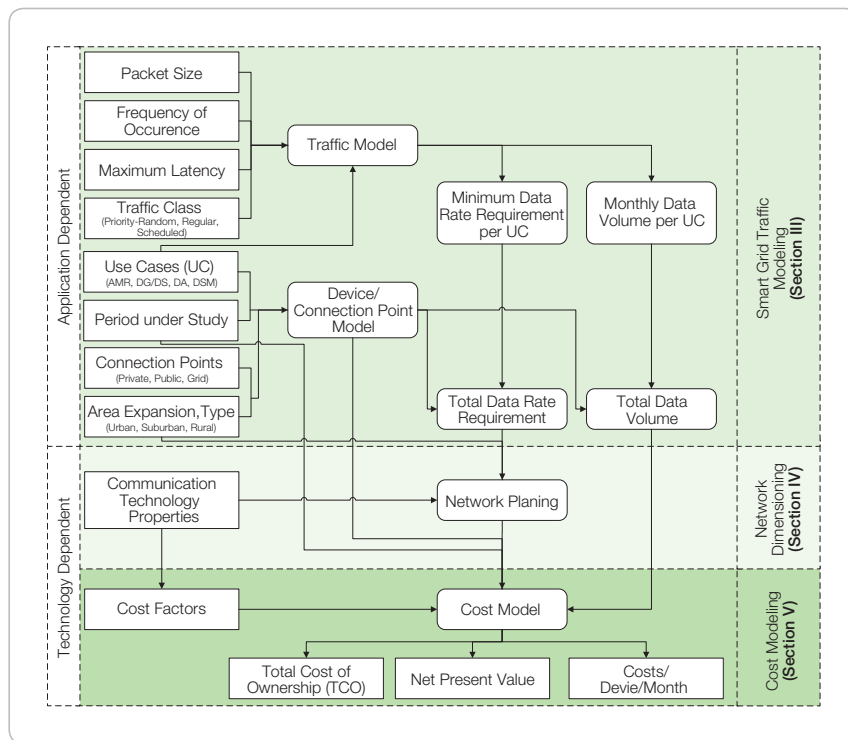

Based on the application dependent communication needs and the available technology and technology dependent costs, a topology proposal is made for different scenarios.



D5.1

Selection of use cases and testing infrastructure at DSOs



To validate and test in the outcomes of PlanGridEV in a real environment use cases for the test beds have been set up. These include operational methods for intelligent charging and active load and congestion management relying on the infrastructure and existing pilot projects by the involved DSOs EDP, ENEL, ESB and RWE.

Depending on the capabilities of the test beds and the opportunities to update them within the scope of Plan-GridEV a detailed description of the test cases has been developed.

The available test beds are capable of conferring the proposed scenarios and use cases. The test beds cover the different scenarios as well as different climate areas and put this in the context of the existing grids of four European DSOs, which can be considered a good and representative sample.

The necessary data to carry out the tests has been gathered and a decision has been taken to which of the test beds is to be used for the evaluation and for which of the scenarios. Additionally, available statistical information on population and weather data for each of the test beds has been collected.

Example for a use case in a test bed

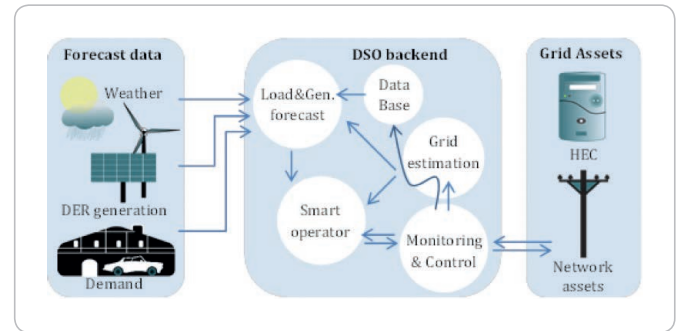

Demand and generation forecast for the following 24 hours is determined and constantly revised by the DSO. A state estimation is calculated every 60 seconds. Following LV network conditions, the DSO controls assets including transformers, switches, public and private EVSE or Home Energy Controllers in order to maintain grid parameters within limits. Decisions are taken by the DSO who is the main actor.

Overview of the scenarios for the test beds

Test Bed	Scenario
Portugal	Conventional-Safe (EV and DER on/off control possible but no reinforcements expected, no EVSEO, no ToU tariffs)
Ireland	Conventional-Safe (charging at nights: kind of ToU tariff)
Italy	Smart Grid – Proactive (no V2G, no competitive market)
Germany	Proactive – Smart Grid (no V2G, no competitive market, centralised power control, provider of the service is the DSO, charge modulation is conducted by the HEC)

Infrastructure and system updates



For the Italy test bed, based on the use cases selected in PlanGridEV, the execution of the demonstration requires a real time Low Voltage (LV) Distribution Management System (DMS) in order to deliver a proof of concept of the service “Planned Demand Response: Enhanced RENs (Renewable Resources) integration”. Alongside the LV DMS to deliver the service described above, there are some technological enablers that are already in operation as part of Enel’s infrastructure for electric mobility. These are: a real-time monitoring, operation and maintenance back-end system for EV charging stations; a real-time communication uplink between EV charging stations and operation back-end; a communication protocol capable of hosting Power Modulation Level object; and a charging station capable of receiving a Power Modulation Level object and converting it through a PWM signal, in accordance at least with ISO/IEC 61851-1 and possibly with ISO/IEC 61851-23 and/or ISO 15118.

For the Germany test bed a lot of new smart equipment has been installed in the LV Grids of the Smart Operator Project: intelligent meters; adjustable on-load transformers; network storage; low voltage switches; and Home Energy Controllers (HECs). These technologies have been selected according to the grid area and have been used either in combination or separately. The central controlling function is carried out by the installed Smart Operator.

The Irish test bed is used to evaluate the Conventional and Safe scenarios. The test bed consists of one site where three electric vehicles are deployed on a 33kVA MV/LV transformer fed from a single phase spur on a three phase MV network which feeds four residential customers. The demonstration consists of four stages: no electric vehicles connected; electric vehicles deployed but charging restricted; electric vehicles deployed with unrestricted charging; and intelligent charging. From a DSO point of view, a monitoring device which records power, current and voltage is installed on the LV side of the 33kVA transformer, and an end-of-line monitor is installed in the property of the customer, furthest from the transformer, to monitor the end-of-line voltage. The monitoring device at the transformer uses ZigBee wireless communications and a cellular modem to transfer the data.

Finally, the Portugal test bed development aims to lower the impact of EV penetration by postponing or avoiding “copper” investments in order to sustain EV adoption. The proper allocation in the LV grid of the charging demand and PV generation within the day would allow the DSO to keep the LV and MV grid with today’s configuration, without replacing transformers or lines that would otherwise be overloaded due to EV charging. As all the tests have been performed with the EDP software planning tool DPlan, no particular technical updates (electric infrastructure or ICT technologies) were needed to develop the tests.

Four scenarios implemented in four PlanGridEV project regions

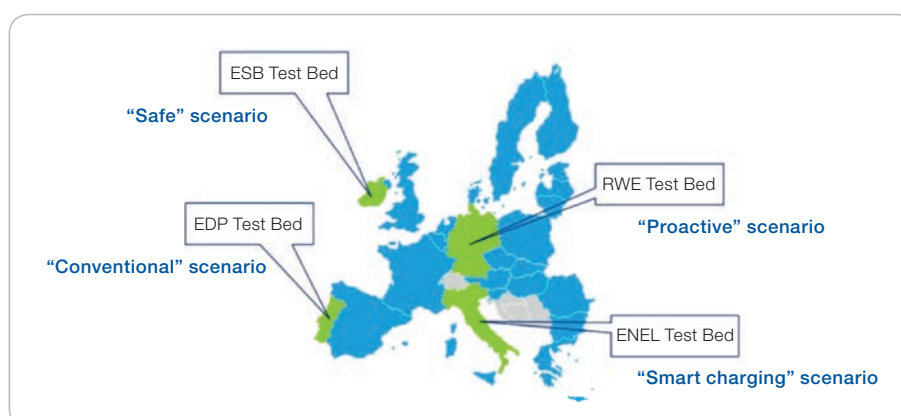

Validation and real testing



The infrastructure and system updates have been implemented and the operational methods deployed in the test beds environments have been validated. Field tests and simulation results have been carried out to assess the influence of different implemented solutions and the effect on selected KPIs are described.

Within the **EDP test bed**, genetic algorithm optimisation methods of DPlan were used to optimise the network topology and to minimise the number of voltage violations during the peak period. It could be shown that changing the network topology during times of high penetration voltage and load violations were reduced. The necessary changes optimised the grid's topology.

Using new infrastructure implemented, the Safe Scenario was tested and analysed within the **ESB test bed**. Within an unrestricted scenario the customers' preferences and behaviours were captured and a typical load profile of the

EV customers is shown. In comparison with other scenarios the influence of an introduced load management was carried out. The need for network reinforcement whilst accommodating EVs on the rural network was reduced. From a voltage quality perspective, the operational method introduced for the Safe Scenario is most optimal.

The Smart Operator installed in the **RWE test bed** helped to stabilise low voltage grids by means of existing flexibilities from consumers, switching actions and the use of batteries. This stabilisation was enabled by detailed information about the current grid state, forecast (both weather and consumption) and the learnings from historical grid data and an ongoing evaluation the effectiveness of past controlling actions (self-learning algorithms). Therefore Smart Operator optimised grid operation and provided a new tool for grid planners beside the conventional grid development when dealing with voltage limit violations and thermal overload of lines.

Power profile without the Smart Operator

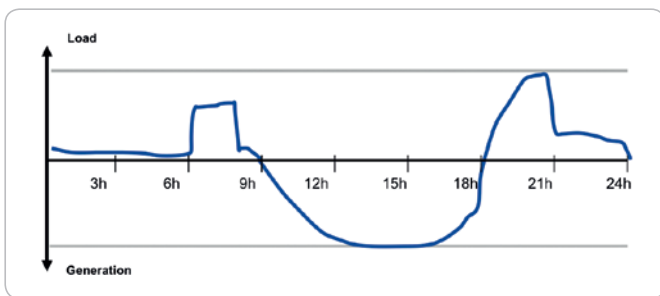

Smoothed power profile with the Smart Operator

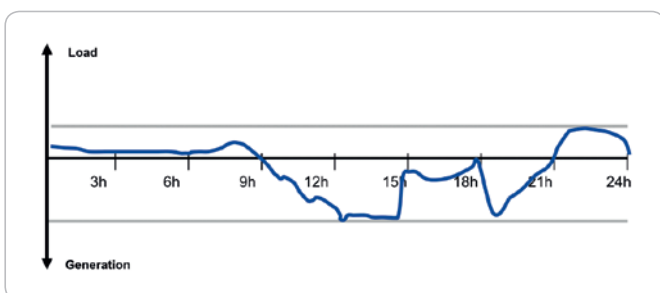

Smart charging and power control applied with SmartOperator at RWE has proven a great potential of smoothing the load profile throughout the day.

User interface of a grid-friendly charge pole

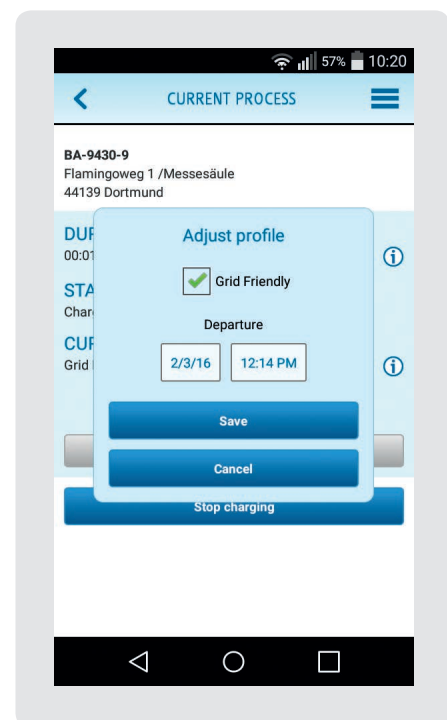

Examples from the UI of the ADMS implemented as a part of PlanGridEV at ENEL.

The **Enel test bed** is focused on smart charging. The specific functionalities developed in ADMS were used to simulate future expected e-mobility penetration as well as increasing RES on the grid to analyse how the recharging modulation varies. The violations among the network before the EV penetration and after the introduction of several charging stations with a 24 hour recharge profile could be compared as ADMS allows the study of each HV/MV node, providing the violations of each single element for the MV and LV network. These violations were translated into reinforcements, which are calculated for two cases by the ADMS algorithm, the BaU and the Smart Charging scenario. It could be shown that the violations in future scenarios decrease with smart charging.

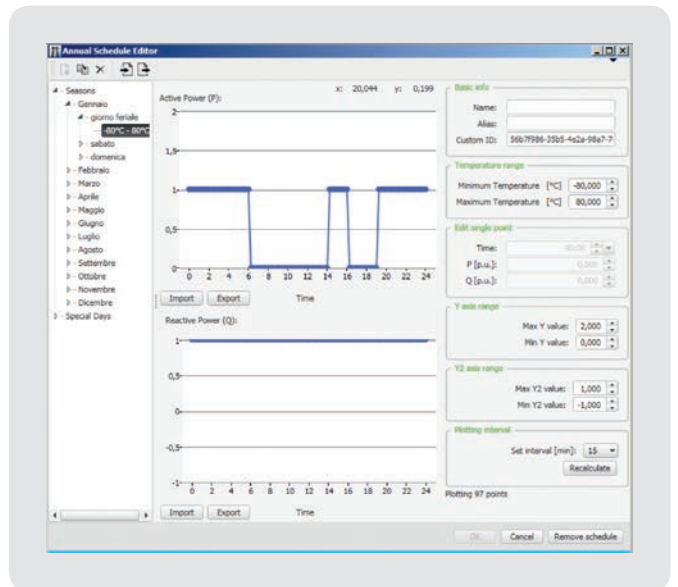
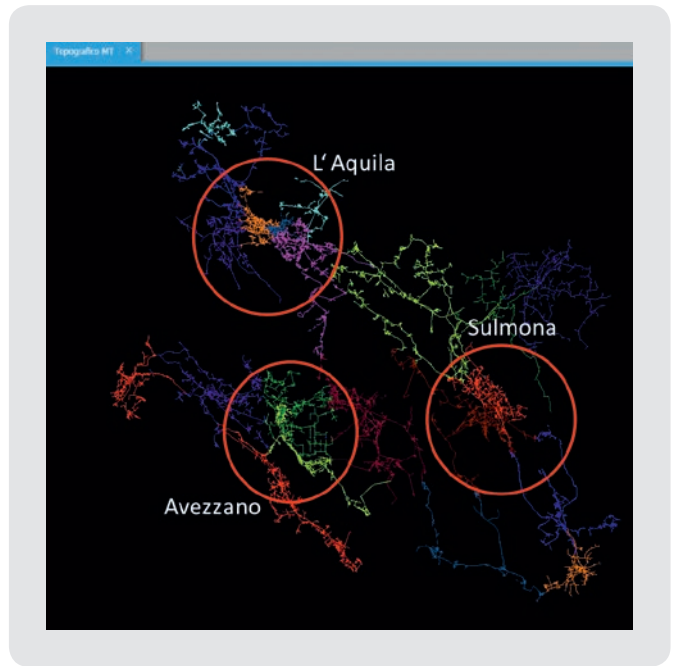

Computed Load Curve

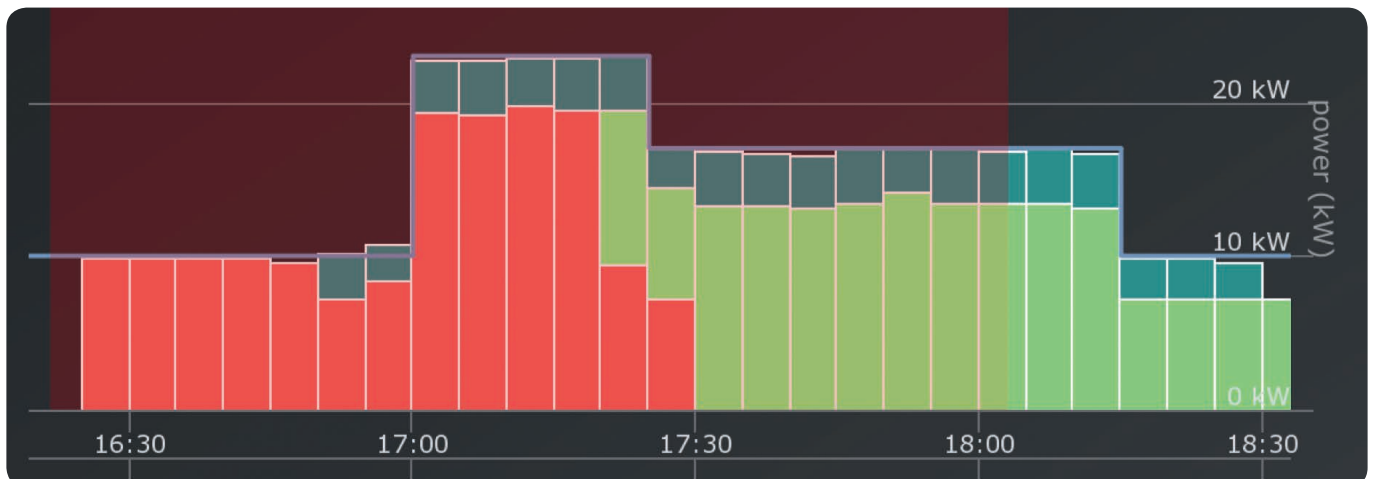

The purple line shows the grid's maximum consumption and the coloured columns indicate the modulation that Enel Mobility Management (EMM) will apply to each EV in order to respect the grid and EV users' needs.

Optimised and enhanced grid architecture for electric vehicles in Europe



The overall objective of PlanGridEV was to develop new network planning tools and methods for European DSOs for the optimised large-scale roll-out of EVs in Europe whilst at the same time maximising the potential of DER integration. To be able to reach this goal, an optimised and enhanced grid architecture for EVs in Europe has to be considered.

The architecture model developed for PlanGridEV is a generic approach in respect to the Smart Grid Architecture Model (SGAM). The aim of this approach is to provide a framework for the further investigation of selected use cases which allows implementing and comparing scenarios of different DSOs. Following a smart grids approach, the developed grid architecture implements energy grid entities and ICT components. The network types used for this architecture are following the SGAM and Smart Grid Standards Map approach. However, for the purposes of PlanGridEV and to increase the readability of the architecture by focusing on the most important networks only, their number is limited to a few selected types. Interfaces or connection points (e. g. via the SGCP) at clusters and interconnections to other clusters are dependent on the scenario. Similar to the SGCP, which represents the interface between clusters, for the intra-cluster ICT the concept of an integration bus is introduced. The introduction

of an SGCP and integration bus also simplifies the implementation process of use cases and scenarios since complex ICT architectures are reduced to a minimum. In contrary to the Smart Grid Standards Map, advanced metering infrastructure is not represented by its own cluster.

Since this architecture focuses on an optimised situation in the future, clusters within the lower levels of the grid are considered to be partly or fully automated. This is also reflected by the naming of some of the clusters (e. g. Industrial or Home & Building Automation). For increasing the readability, interconnections ICT network are reduced to network type interfaces. Since the specific ICT configuration depends on the scenarios and use cases, this approach provides the necessary flexibility to address specific configurations. The e-mobility infrastructure is located on the border between DERs and the consumption domain. Since EVs are considered to be not only consumers but also generators (V2X) the allocation of this cluster to this position is suitable.

The architecture considers and implements all four categories of the smart grid strategies. Automation on the distribution level, but also at the consumption domain, is part of this approach, as is the integration of DERs.

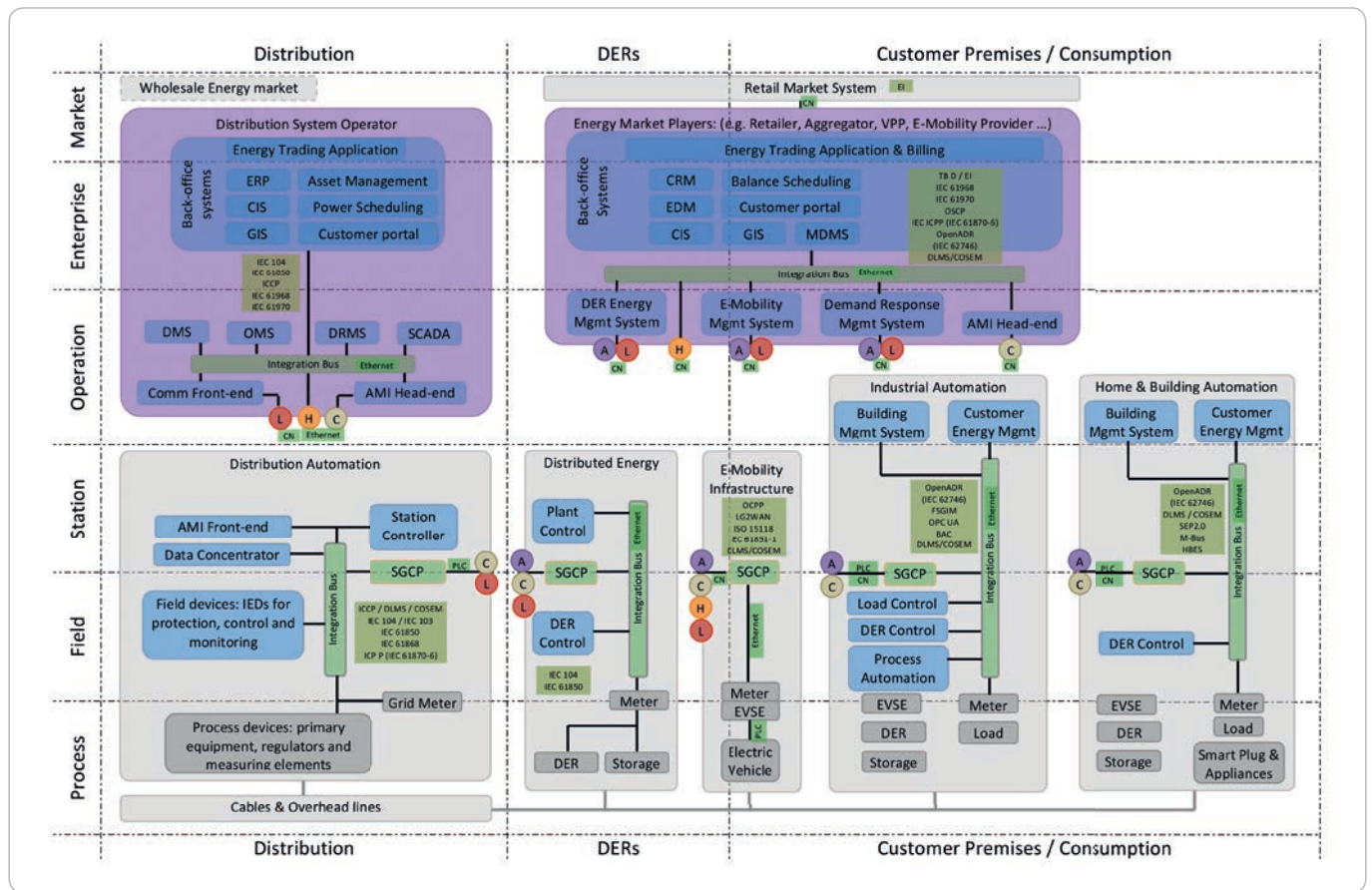

The empowerment of customers is reflected in several perspectives. Clusters at the consumption domain are considered to feature a certain level of automation and can implement systems from DER or e-mobility infrastructure clusters. Additionally the SGCP interface allows communication to external parties (e.g. market players) and the forwarding of relevant information regarding remaining flexibilities (optional after potential self-optimisation management procedures). With the exception of the Advanced Metering Infrastructure (AMI), these categories are directly represented within the architecture as specific clusters or domains. The AMI is considered to be an integrated part of the architecture and is distributed and implemented within all relevant clusters.

Since the architectures aim is to function as a framework for investigating different approaches and scenarios, this model does not imply a specific optimisation hierarchy or strategy. However, from the entities at the cluster it can be derived that most domains contain multiple levels of optimisation options distributed across different zones. This considers and allows different optimisation strategies which can be centralised or more distributed approaches.

This also includes optimisation and automation at the lowest levels of the network hierarchy.

Flexibility services can be mapped to this architecture and clustered within specific use cases. In general, commercial and technical use cases can be distinguished. Whilst commercial services are addressed by markets, only some of flexibility services in the technical use case are market products and the rest are fully automated functions (e.g. fault management) at the zones field or station within the domains distribution and/or transmission. Additionally to these two use case clusters, a third field of applications for flexibility can be identified which is expected to increase in importance in future. Self-optimisation at the consumption domain, including DERs (incl. stationary storage systems) and e-mobility infrastructure is related to the technical use cases, since involved systems will follow the signals of local management systems. However, the reasons and strategies for optimising can also be of commercial nature. Overall, provision, usage and use cases of flexibility affect all domains and zones of the smart grid plane.



Analysis and performance evaluation as a basis for further recommendations



The PlanGridEV prototype allows the quality of the investment candidate solutions to be assessed. It optimises the operation of the system and is based on grid operation simulation, which takes the flexibility of controllable resources into account. The problem is tackled as an optimal power flow problem.

Several EVs charging modes related to different charge managements, from “conventional charging” to “smart charging” as well as real distribution networks have been modelled and simulated with the prototype tool. (In order to be representative of European distribution networks, small and large cases, urban and rural, low voltage and medium voltage, networks which are related to the EV test beds of this project have been simulated and include EVs and DERs.) For each distribution network modelled, a reference case has been built and simulated. Then a sensitivity analysis has been carried out, based on the prepared reference case.

The experience showed that the tool has been capable of simulating massive EVs deployment in a distribution network. Based on the feedback from the simulations, the prototype tool has been continuously improved. It has been benchmarked and validated through several test cases. Some key parameters have been highlighted, such as the strategy of charging car batteries during the day.

The analysis of the results of the simulations and the underlying comparison has highlighted some interesting results.

First of all, the simulations have shown that existing European networks can absorb a low or moderate level of EV deployment without any major issues, as the existing networks present a sufficient margin.

An increasing level of EVs in the distribution system with a conventional charging mode gradually saturates distribution feeders and transformers. Furthermore, increasing

Examples for analysed cases

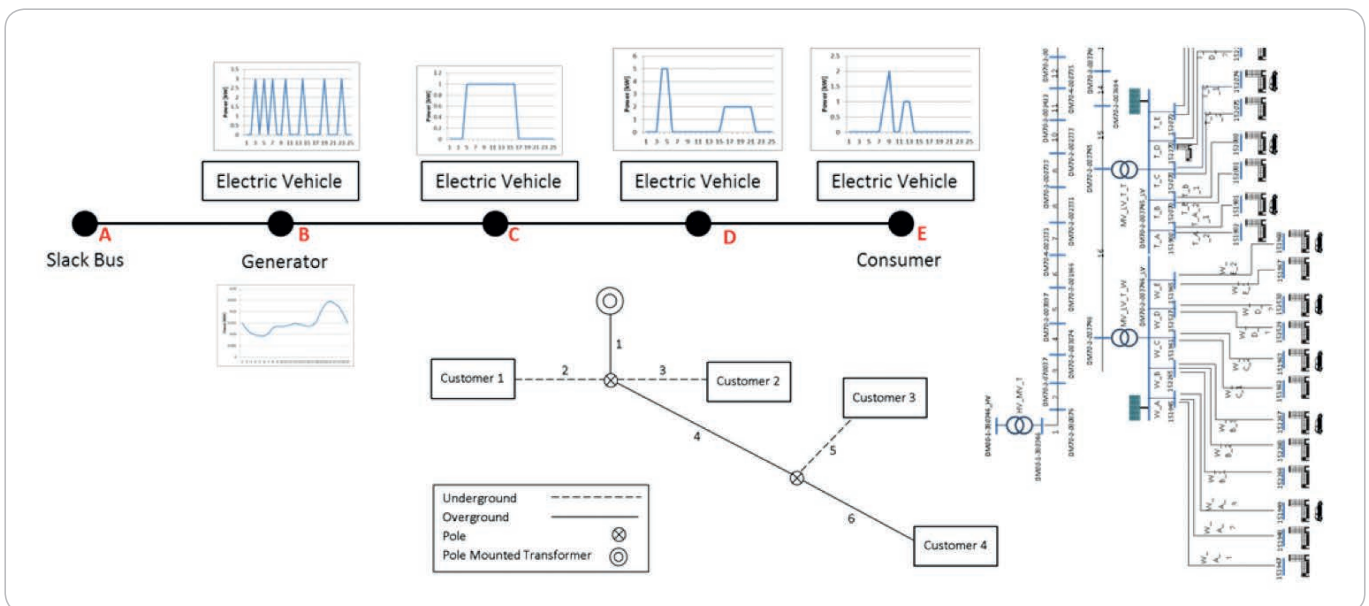

Small and large cases have been built to test the prototype tool. Low voltage and medium voltage networks have been simulated including EVs and DERs. The tool allows a detailed analysis of the impact of EV deployment, the interaction with local generation, and the way smart grids can improve EV deployment by bringing flexibility into the distribution system.

voltage drops leads the system out of the contractual limits defining the quality of electricity supply. Another impact is obviously the increase of the losses and thus a decrease of system efficiency.

Simulations have shown that smart charging significantly decreases the negative impact of large EV deployment. For a same number of EVs, the saturation of the transformers and conductors improves. Voltage and electricity profiles can be positively influenced by smart charging. Consequently, smart charging allows a delay to the reinforcements by avoiding an increase of the peak caused by possible EV charging simultaneously with the peak load. The presence of EVs increases the DER hosting capacity of the system as smart charging allows charging the EVs in adequacy with the DER generation. Reverse flows are thus decreased. Finally, smart charging has a positive impact on the losses by reducing the direct peak and the inverse peak.

RWE test bed – Smart Operator

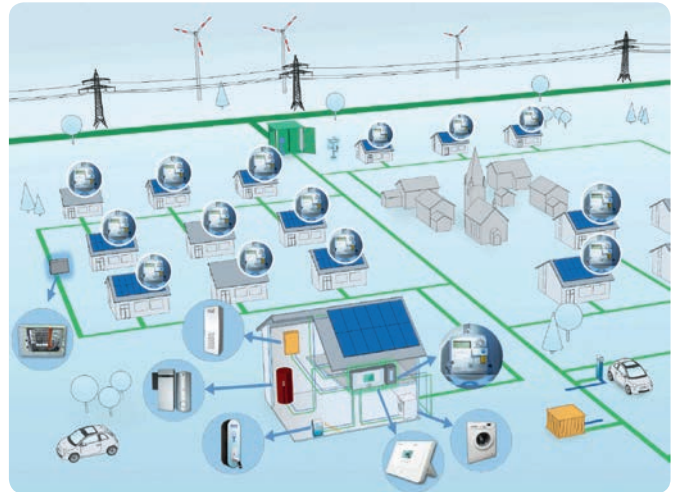

This figure gives a schematic overview of the smart meters and actors e.g. EV charging, home battery storage and heating systems implemented in the Smart Operator test bed at RWE as part of PlanGridEV.

Comparison between conventional and smart charging modes

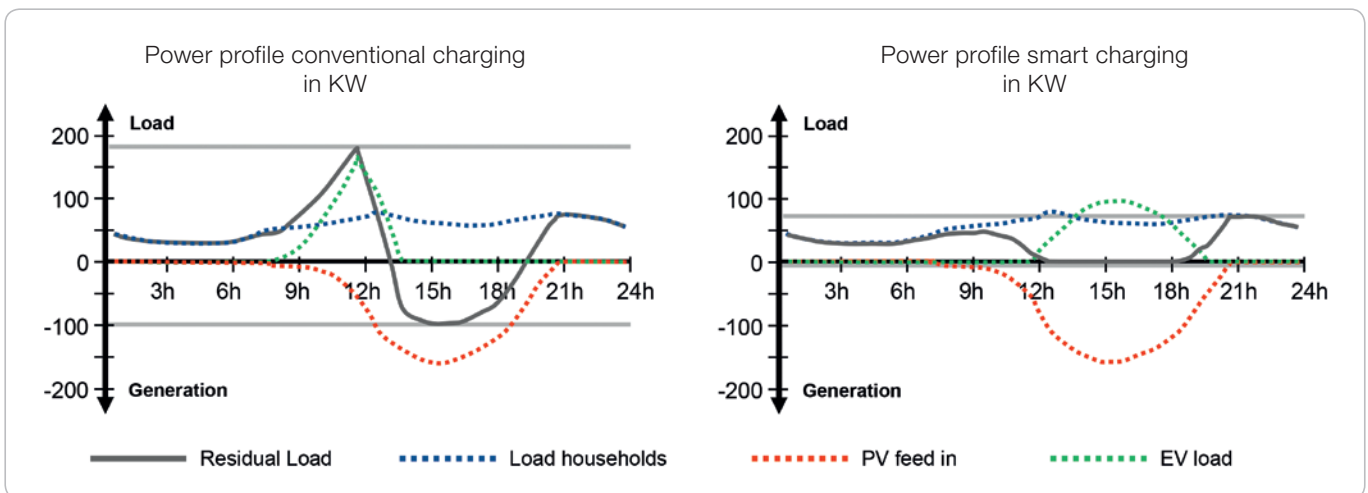

Smart charging reduces the load by 50% and eliminates the grid feed-in completely in this example.



Findings from simulation



1. A low level of EV deployment does not significantly impact the distribution system

Existing distribution networks accept a low level of EV deployment with limited adaptations

Low EV deployment does not significantly impact the distribution network thanks to the available margin of most existing distribution networks.

Low impact of the type of charging mode (conventional or smart charging) of EVs

The benefits of the smart charging mode of EVs are thus limited in this case, as shown by the simulations carried out in the section Deliverables D6.2.

The planning of the distribution network is minimally affected for a low or moderate number of EVs expected.

2. A large deployment of EVs has mainly negative impacts on the distribution system, with conventional EV charging

Impact of EV deployment on the load forecast

An adequate load forecast is at the base of all planning methods of distribution networks. The deployment of EVs, as additional load, impacts both the peak load and the total energy consumed by modifying the load curve shape.

Power charging of EVs and battery size

Above the number of EVs expected to be connected in the system, the rate of charge and the battery size are directly of significant importance.

The load forecast phase of the planning must include properly the expected electric vehicle load. That load depends of the number of electric vehicles, the daily driving distance, the type of charging, the size of the battery, etc. The method of load forecast must be adequately chosen.

Thermal limit violation of transformers and conductors

In the planning phase, the load forecast must consider the deployment of EVs in the distribution network. The higher peak load will increase the needs of reinforcements in the system to avoid saturation of the transformers (HV/MV and MV/LV) and the thermal limit violation of the conductors.

Voltage under the contractual limits

Furthermore, voltage drops on the feeders in both medium and low voltage levels are reinforced by the deployment of EVs when no strategy of charging is defined, i. e. under conventional operation.

In the short term, and beyond a level of deployment, saturation of transformers and/or of conductors will impose reinforcements that are not planned in the network development plan. Some foreseen investments will have to be advanced.

EV charging will have a significant consequence on the needs of reinforcements, especially with conventional charging for a high level of EVs.

Medium and low voltages

Both medium and low voltages will be affected by the deployment of EVs.

The planned optimal density of MV/LV stations and of HV/MV stations per customer will be affected by the EVs deployment characteristics.

Rural areas are more affected than urban areas

New load is added by the EVs charging to the system in low and medium voltages. Rural networks are characterised by long feeders which are mainly affected by high voltage drops and may be more sensitive to a large deployment of EVs.

Traditional planning rules in rural areas, for example, maximum length of one feeder, loading rate, etc. may no longer be valid in the case of high EV deployment.

The global efficiency of the system is affected by an increase of the peak load

Under the conventional charging mode, the charging is done at fully capacity when needed and not necessarily in conjunction with the rest of the system. It is thus expected that there will be an increase in peak load and of the rating of the transformers and of the conductors, which leads to an increase of the losses as compared to the load.

The deployment of EVs and the associated cost of losses will require a new assessment of the optimal rating of conductors and transformers allowing an optimal total cost (CAPX and OPEX) of the system.

The charging rate of the battery of the EVs can positively or negatively impact the needs of reinforcements. The rate of charging in the conventional mode impacts the peak load. High charging rate means high flows in the system. However, as the time of charging is divided by two, a high rate of charging can avoid a situation with numerous EVs charging in the same time at some hours.

Depending of the cases, it can positively or negatively affect the system. In all circumstances, it must be considered in the planning.

The capacity rate of EV charging must be included in the planning phase.

3. Smart charging decreases the negative impact of large EV deployment

Smart charging positively impacts the needs of reinforcements due to EV deployment

Smart charging allows a delay to the reinforcements by avoiding an increase of the peak caused by possible EVs charging simultaneously with the peak load. Simulations have shown that the shape of the load curve with EVs smart charging is considerably softened compared to conventional charging.

For the same number of EVs, the saturation of the transformers and conductors improves with smart charging compared to conventional charging. Compared to the case of conventional charging, smart charging will require less planning of network developments for the same level of EVs.

Charging mode of EVs is of prime importance when planning a distribution system.



4. Smart charging allows taking advantage of EV deployment in case of generation in the system

The presence of EVs combined with smart charging increases DER hosting capacity in the distribution system

A high level of DER in the distribution system can cause overload of conductors and transformers and causes a significant increase in voltage. Generation curtailment could be necessary in order to keep the system within technical contractual limits.

Voltage- and electricity profiles can be positively influenced by smart charging. Smart charging of EVs maximises the adequacy of the load and of the DER generation. It brings flexibility and improves global performance of the system. For instance, charging of EV batteries in adequacy with solar PV generation will avoid possible inversion on the power flow into the transformers.

Reciprocally, high DER penetration allows a higher EV penetration when compared to a case with no DER

Maximising the adequacy of the DER and EV charging allows both a high level of DER and EVs. Smart charging is necessary to maximise this adequacy.

Charging of the EVs batteries in adequacy with generation will moderate or delay the needs of reinforcements in distribution networks.

Smart charging has a positive impact on the losses by reducing the direct peak and the inverse peak

The increase of losses due to the deployment of EVs stays limited with the smart charging mode. The number of EVs charging during the peak load is maintained limited. The global curve (standard load and EVs) is softened. In other words, smart charging increases the load factor of the distribution network.

As the calculation of expected losses is a necessary step in planning, all elements affecting its evaluation must be considered, such as the number of EVs and how there are charged conventional or smart charging.

Adequacy of decentralised generation and EVs can be maximised through incentives

EV consumers can be incentivised to charge accordingly to the DER generation. The charging modulation should be optimised in order to ensure an effective DER penetration. This is allowed by smart charging which offers the provision of more services.

With smart charging, a price strategy can be defined to capture the local decentralised generation into the EV charging process, especially when the PV generation is high and not absorbed in the local consumption.

Incentives and tariffs schemes have strong impacts on charging behaviour and thus have a direct influence on the load forecast and consequently of the long term sizing of the system.

5. Presence and location of public charging stations as a key factor for the distribution planning

The presence of public charging stations has many advantages

Without the possibility to charge EVs in public stations or at work, charging can only be done at private stations at home, and realistically, mostly in the evening, when people come back from work. With smart charging, the charge will occur in the late evening and during the night in order to significantly reduce the traditional peak load of the evening. With conventional charging, the charge will be done directly on arriving back home and at maximum

power, increasing the peak load and the associated losses. In these conditions, reinforcements in the distribution infrastructure will be quickly required.

Public stations and work stations that are connected to the medium voltage network will avoid part of the charging need at home, in other words it will limit the impact of the EVs' deployment on the low voltage grid (which will obviously also impact the medium voltage network).

Public charging station allows adequacy between EVs charging and solar generation

Relevant to private charging at home as a large number of cars are not at home during the day, most of the charging cannot be in adequacy with solar generation.

The location of the charging station influences the planning

Furthermore, charging facilities located at the right places can:

- > Encourage the charging on stronger medium voltage feeders;
- > Facilitate higher DER penetration with smart charging of EVs closer to the decentralised generation.

The presence and location of public charging stations is a key factor for planning and a measure to be considered a large deployment of EVs is to be allowed in the distribution network, while limiting negative impacts and benefiting from the positives.

6. The rate of deployment of EVs in the distribution system impacts planning

The time horizon of distribution planning is mid- and long-term. In the short-term, the development plan of the distribution network is adapted, but with a limited margin.

As seen in previous chapters, the presence of EVs impacts negatively and positively on the distribution system. For a fast EVs deployment, non-initially planned reinforcements will be quickly required.

The rate of EV deployment is another subject impacting the planning of the distribution network.

7. Conclusion

The deployment of EVs in European distribution networks will have a significant impact on network operation. This impact must be taken into account at every step in the distribution systems, and particularly in planning phases. Large scale deployment of EVs is a great opportunity, as is the coupling of EVs and DER, which, thanks to smart grids, allows the increase of the hosting capacity of both DER and EVs.



Novel planning rules for EVs in smart grids



The roll-out of electric vehicles is a major opportunity when trying to decarbonise industrial countries. Car manufacturers have substantial progress over the past few years in designing electric vehicles for the market and big utility players such as EDP, ENEL, ESB and RWE have put in a lot of effort to provide these new electric cars with an appropriate infrastructure.

Even though the first charge poles for EVs in a grid have very little influence on the distribution grid, it does not take much to get into severe overload situations when putting up a charging infrastructure. Usually, extension of the grid can be postponed or avoided altogether if the charging infrastructure is capable of modulating the power drawn by charging cars with the needs of other customers.

This means that a large amount of grid extension costs can be reduced with intelligent control schemes imposed on the charging infrastructure. These can be executed without running into problems fulfilling the cars' energy needs.

Grid planning needs to use this information and invest in controllability instead of "copper" to extend the grid. The ideas for decentralised control like RWE's "Smart Operator" are as suitable a solution as the ADMS extension approach by ENEL has proven to be. DSOs need information about future demand as well as PV and wind generation in the near future as well as the resulting transformer load, in order to influence the charging process in a proper way. Besides this, DSOs should also have an eye on metering processes related to the charging infrastructure. If there is no qualified metering implemented at the charging infrastructure it might end up that there is no way to influence charging schemes with monetary incentives since there is no way to calculate the incentives. They should insist that qualified and certified metering suitable for time variant tariffs, is used by charging infrastructure operators.

Looking at customers makes the set-up more challenging. They do not simply want energy for their cars; they want it when they need to travel and when they have the time to charge. Here it is necessary to distinguish between two scenarios: charging while the car is going to be parked. Anyway, which usually provides some time in which the charging progress can be optimised; and on the other hand, fast charging where the driver only stops to get the car recharged, for example at a DC fast charger. This latter scenario is particularly challenging since the energy has to be provided from an unsteady, renewable source. The traditional fuel station model might be what customers and some car manufacturers still have in mind but that is not going to be the solution. If the target is to charge a battery for 500 km within three minutes like the people are used to from their old car, it will be necessary to have 1.8 MW charging power to hand. This is the same amount that utilities calculate to connect 1,000 households to the grid! So beside the fact that this power might not be available from renewable sources when needed, there would be the necessity for major grid extensions to fulfil these needs.

So it is necessary to create charging occasions where less power is needed and where there is more time for charging. To still provide the flexibility that customers ask for, charging will occur while the car is planned to be parked anyway.

To build this scenario a major change has to be executed for the distribution grids. While today, there usually is no measurement or control in the distribution grid in the future there will be the need to know which reserve is available for controllable loads in the LV grid and there is a need to transport this information to the customer.

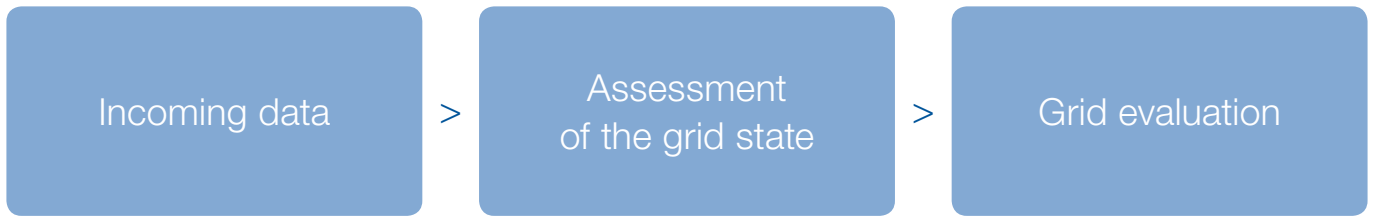

Timeline

Since EVs have arrived to the market already and a charging infrastructure is in the progress of being implemented there is no time to be lost with further investigations. The implementation of a grid-aware and integrated EV charging infrastructure has to start now. Usually it takes a while until all market players adopt to new rules, the more infrastructure introduced that is incapable of being controlled by the DSO, the higher the costs for replacement later on will be.

Interfaces

Interface with TSO

Even so, EV, as with PV installations and wind generators, are mainly connected to the DSOs and there is an increasing interest from the Transmission Systems Operators (TSOs) regarding this topic. This arises from their understanding of regulation and different system entities since system stability was mainly secured by strong power plants connected to the transmission grid. This means there is no way of ignoring the role of renewables in the system any longer. In Germany for example, there is a peak load of 80 GW and 70 GW of renewables installed.

This results in interesting challenge due to the conflicting roles arising from the fact that now a major share of the system-relevant power generation takes place in the DSO grids. For this reason the TSOs try to influence the transmission and distribution grid codes at EC level to put them into a position where they can at least fulfil their role. Taking into account the findings of this project, a far more interesting approach could be to divide the role in the future, describing interfaces between the TSO and the DSO role.

For this reason we propose the definition of an interface between TSO and DSO which ensures a negotiation between TSO and DSO if a TSO needs to interact with generators in the DSO grid for system stability reasons. Thus also a DSO gets a system stability role in the future.

Interface with DSO

In the same way that the TSO needs interfaces with the DSO in future there is a similar need for the interface between DSO and charging infrastructure operators. Due to the different necessary charging facilities (public, semi-public, private) PlanGridEV analysis show that the control of these does not necessarily need to belong solely to the DSO. For example we assume, that charging infrastructure on the campus of a supermarket or an industrial plant will somehow be connected to the maximum power of the plant; it therefore not only interacts with the DSO but primarily with the other demands of the company. For this reason, DSOs will need to implement interfaces for charge control or demand control to which charging infrastructure operators can be connected.

Financial incentives for infrastructure should only be given to charge pole operators that have a valid and proven interface to the DSO because otherwise there is no usable optimisation of charging EVs at DSO level. Due to the benefit of such an interface it might even be thinkable to empower the DSO to pay an incentive to those charging infrastructure operators or to reduce their grid fees since there is an overall benefit to society resulting from reduced grid extension costs.



EV-Grid integration best scenario and its investment strategies



The aim of PlanGridEV is to facilitate the widespread adoption of electric vehicles (EVs) by improving their integration in distribution grids. Therefore, the project is expected to remove one of the potential barriers for electro-mobility. However, other barriers, such as the uncertainty surrounding the economic feasibility of deploying publicly accessible charging infrastructure, may still remain. In order to overcome such uncertainty, an economic assessment of the smart charging of EVs has been carried out.

The assessment is based on the results of the FP7 Green eMotion project. The main conclusion was that the business case of public charging as a stand-alone business can only be profitable in the mid-term in the case of highly frequented charging stations (Electric vehicle Supply Equipment – EVSEs). The assessment found that EV charging businesses were only profitable if the average use of EVSE (for the cases of traffic hotspot charging, highway charging and home charging) involved between three and six charging events per day. So, in the short term, alternative options such as advertising or linking EVSE operation to commercial activities e.g. shopping or dining are recommended. The economic assessment in PlanGridEV investigated whether the provision of services for grid support can also play a role in improving the business case of the charging service operator (EVSEO).

Based on the previous studies of the project, the smart charging of EVs was selected as the PlanGridEV best EV charging scenario. This was used to perform a bottom/up analysis that look into account the technical constraints in the medium voltage (MV) and low voltage (LV) grids. In the PlanGridEV best charging scenario, a cluster of EVSEs is properly managed by a EVSEO, simultaneously taking into account the EV customer preferences and the DSO power flow constraints into which information on RES availability and the current status of the LV/MV electricity grid where the EVSEs are installed is fed. By using an intelligent distribution network management system, the DSO knows the needs and the status of the grid in each load area, including the power availability for EV charging, so that it can create a target load curve. On the consumer side, EV customers define their EV charging requirements, which are collected through an additional management system that takes care of electro-mobility (including the management of EVSEs). This additional system to manage EVs also receives the load curve created by the intelligent distribution network management system, which is then used to modulate the recharging processes of the EVSEs included in the defined load area. By modulating the recharging processes, demand peaks in the grid can be avoided and distributed energy resources (DER) can be better integrated.

Smart charging – constraints-based EV load management for enhancement of DER integration

Considering the information from consumers regarding their travel needs, the grid capacity and a forecast for foreseeable renewable generation, the integration of the Enel Mobility Management system (EMM) and the Advanced Distribution Management System (ADMS) deliver great potential for optimisation.

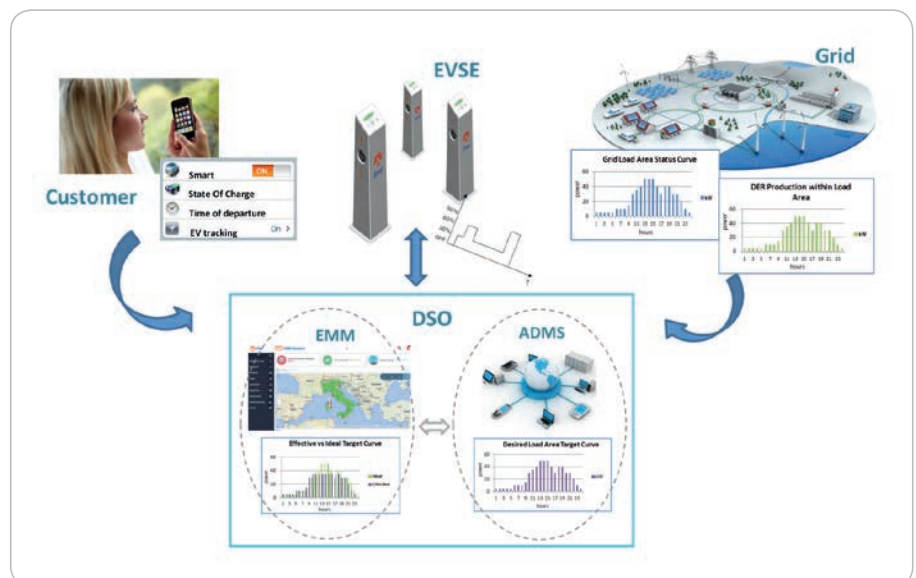

e³value model for the provision of smart charging services

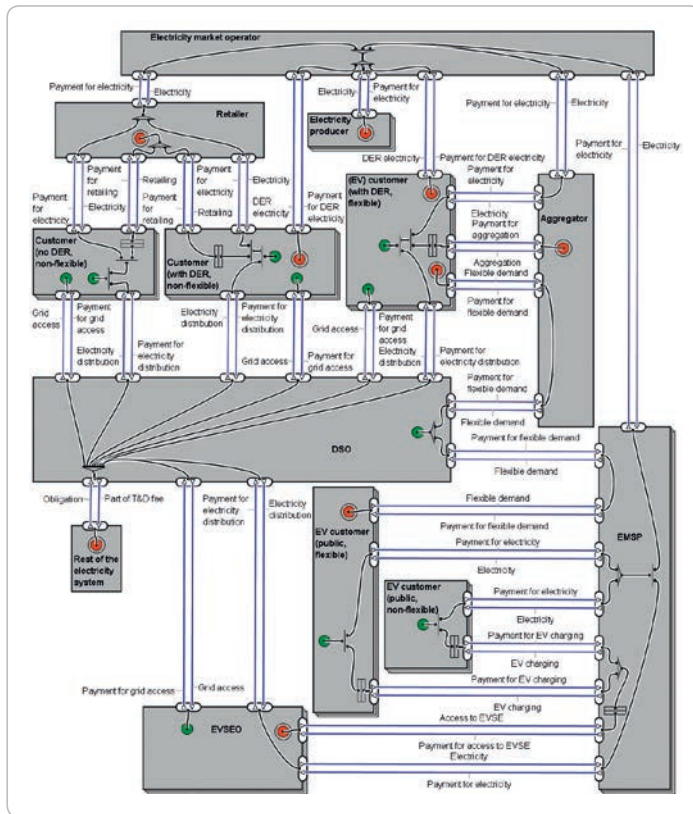

Taking all the actors, restrictions and demands into account leads to very complex and challenging models which have to be solved in real time to provide the desired services. A major challenge here is the number of actors interacting even the most in simple use cases.

In order to derive actual results for the best EV charging scenario, the test beds were considered. The topology, characteristics and data from the real network were considered and a potential future scenario for EV penetration was defined.

By modulating the power output of about 10% of the EVSEs, for four hours per day in each of them on average, the number of violations in grid elements can be reduced by about 17% compared to the Business as Usual (BaU) scenario, leading to 5.8 million euro savings. If 16.5 MW of PV are inserted in the grid, there are fewer violations in the BaU scenario, but the impact of modulating the power output for EV charging is very similar.

By extrapolating those results, for instance, to Italy, the benefit could amount about 1040 million euro. In order to exploit these benefits, the distribution network must be transformed into a smart grid, by deploying the required Distribution Automation (DA) systems. These systems require an investment of about 3610 million euro, but can save about 216 million euro per year in operational expenditures. Overall, the annual benefit of the smart charging of electric vehicles is expected to be in the range of 49 million euro. Taking into account that there are about 36 million modulation events per year, the net benefit per

modulation event is about 1.36 euro. The DSO may pay about 1 euro to the EVSEO for each modulation event, which results in about 2000 euro per year per EVSE. The benefits resulting from EV charging modulation can then be distributed among the different stakeholders in the electromobility ecosystem.

In low-penetration scenarios, existing distribution grids are expected to be able to cope with EV charging demand, without the need to receive grid support services. Moreover, publicly accessible EVSEs are not likely to be used frequently, so their operation is far from profitable. However, when the penetration of EV customers is in the order of 10%, the expected number of charges per publicly accessible EVSE increases significantly, at least in urban environments: 3.27 charges per day in the traffic hotspot case and 4.51 charges per day in public EVSE for street side parking (which, considering two overnight charging sessions, leaves 2.51 daytime charging sessions per day). These EVSE usage rates are not enough to make EVSE operation a feasible business, but the additional 2000 euro per year which can be obtained from the provision of grid support services make EVSE operation a feasible business in most of the cases (except in the highway case, where 0.173 charges per day are still too few to make it profitable).



Roadmap and recommendations for innovation, regulation and policies



Two main research and development paths have been followed during the PlanGridEV project with regard to the proper management of concurrent EV mass market uptake and renewable source integration:

- > The first, aimed at evaluating the best planning rules within a Business as Usual (BaU) approach in order to cope with electric vehicles uptake, leveraged the tool developed in the project and delivered insights to modern Distribution System Operators (DSOs) in order to plan the electricity grid accordingly in the near future.
- > The second path was aimed at researching and delivering proof of concept of operational methods which might involve EVs as controllable loads. This was to serve the purpose of implementing supporting services for DSOs in their operation of large scale infrastructure, minimising capital expenditure which is otherwise the only option in the BaU approach.

This document provides an overview of the recommendations relating to innovation, regulation and policies that are relevant to the implementation of the second path. These involve operational methods by which the DSO could request EVs to be managed and controlled in relation to customer preferences and grid constraints.

Smart charging infrastructure



Innovation

The R&D performed in this area during the project allowed the maturity of smart charging to go from Technology Readiness Level (TRL) 4 to an estimated level of TRL 6, where a series of further innovative actions must be undertaken to bridge the gap to TRL 9 and market reality. Such steps are discussed in the document and can be summarised as follows:

- > To increase EV battery capacity to a minimum level of 44 kWh. This will increase the possibility of monetising the battery by using it as a controllable asset during the initial transition phase of the market, where in some member states it will be unlikely to have more than one EV per each low voltage line that can be aggregated in order to provide active demand service.
- > To establish a common set of interfaces amongst stakeholders, via the standardisation of EVSE-EVSE backend system communication protocol and the implementation of a smart charging server-to-server services protocol standard. Such interfaces shall include EV information such as State of Health, State of Charge, Remaining Time/Remaining Energy and Time of Departure. The latter parameters are key in order to achieve the flexibility that could be provided to the DSOs for the operation of the service.
- > To update the EV-EVSE communication and adopt a stronger mechanism than what is currently available, this would enable EV load controllability with the minimum error in terms of time of reaction and EV set points control. This should be implemented by improving IEC 61851-1 with digital communication both for AC and DC charging and by having ISO 15118 protocol implemented in market-available EVs.
- > To allow the possibility of modifying the EV set points during the charging process for DC charging, a possibility which at the moment is unforeseen, neither in CHAdeMO protocol nor in DIN specifications 70121-2014 (Combined Charging Systems) communication protocols. The possibility to combine DC charging and smart charging (e.g. DC home wallbox) should at least be taken into account.

Regulation

An overview has been provided with regard to possible framework regulation to support active demand services and, more precisely, those based on electric mobility. The recommendations were gathered and cross-checked by means of a survey of electric mobility and electricity market stakeholders. This survey delivered a common understanding of how a smart charging market should be implemented and the conditions under which it should be regulated by national or international authorities, in order to assess this service as a possible means of transformation for utilities and specifically modern DSOs.

As demonstrated in this project, when planning for EV uptake, DSOs face a trade-off between leveraging the flexibility of EVs and performing direct grid extensions. Therefore regulatory discussions should take into account the possibility of evaluating the role of DSOs in financing the establishment of an active demand services market as alternative means to electricity grid reinforcements.

Smart cards currently needed to do test drives in Europe and charge at different charge pole operators



Policies

Smart charging is a set of techniques, or operational methods that have the potential to save European DSOs significant CapEX costs in electricity grid extension. This was demonstrated in PlanGridEV D7.1 and in several other current studies in this area (see “Smart Charging: Steering the Charge, Driving the Change” – Eurelectric – 2015). The costs saved through these techniques could be distributed across the value chain, leading to savings in terms of service fees for consumers.

For this reason, supporting policies might be implemented in each member state that urge the consideration of smart charging as an additional beneficial feature of the EV charging infrastructure under deployment, in accordance with the European Alternative Fuels Infrastructure Directive 94/2014. This could lead to public tendering requirements which recognise the added value of smart charging in terms of tendering evaluation, or public subsidised programmes that specifically request the EV-Grid integration as a mandatory parameter in deployment evaluations, particularly in the uptake of the mass market where the system adoption cost for the electricity system will reasonably be higher.

EV-EVSE communication is needed to allow EVs load controllability with digital communication both for AC and DC charging and by having ISO 15118 protocol implemented in all market-available EVs. The commonly used identification with proprietary smart card id systems is no solution.



PlanGrid EV Deliverables



No.	Name
D1.1	Current requirements, regulatory gaps and expected benefits
D1.2	Future scenarios
D1.3	Gap for Energy Grids and KPI report
D1.4	State-of-the-art methods report
D2.1	EV-Grid Integration Business Scenarios
D2.2	Technical Requirements for tools/methods for smart grid integration of EVs
D2.3	Economical requirements for tools/methods smart grid integration of EVs
D3.1	Joint network architecture model
D3.2	Specification of Energy Grid/Functional & Service Architecture
D3.3	New ICT developments and services for EV integration in electricity distribution networks
D4.1	Report on the definition of the optimization problem and tools specifications
D4.2	Report on new methods to maximize integration of EV and DER in distribution grids (methods for multi-objective optimization under uncertainty, for storage modeling and for representing statistical behavior of EV and DER)
D4.5	Prototype tool for optimizing existing assets using controllable loads
D5.1	Short report on selected networks and use cases for validation
D5.2	Short report on infrastructure and system updates
D5.3	Report on the impact of the validation and real testing
D6.1	Optimized and Enhanced Grid Architecture for Electric Vehicles in Europe including graphical representation and corresponding white paper
D6.2	Analysis and Performance Evaluation as basis for further recommendations
D6.3	Handbook/White Paper of Novel Planning Rules for EV in Smart Grids
D7.1	EV-Grid integration business cases and investment strategies
D7.2	Roadmap and recommendations on innovation, regulation and policies

All deliverables are available via www.plangridev.eu and via www.researchgate.net.

PlanGridEV – Publications, Articles and Conference Papers



- 1 Multi-objective distribution planning approach for optimal network investment with EV charging control**
Dias, A.; Carvalho, P.M.S.; Almeida, P.; Rapoport, S.: in PowerTech, 2015 IEEE Eindhoven, vol., no., pp.1–5, June 29 2015–July 2 2015
- 2 Choice of ICT infrastructures and technologies in smart grid planning**
Stefan BÖCKER, Christian WIETFELD – Communication Networks Institute, TU Dortmund, Germany; Frederik GETH, Pedro ALMEIDA, Stéphane RAPOPORT – Tractebel Engineering, Belgium, CIRED 2015
- 3 EV aggregation models for different charging scenarios**
Marina GONZÁLEZ VAYÁ, Thilo KRAUSE – ETH Zurich – Switzerland; Luis BARINGO, Göran ANDERSSON – Universidad de Castilla-La Mancha – Spain; Pedro ALMEIDA, Frederik GETH, Stéphane RAPOPORT – Tractebel Engineering – Belgium, CIRED 2015
- 4 EV stochastic sampling: addressing limited geographic areas**
Stefan UEBERMASSE, Fabian LEIMGRUBER, Martin NOEHRER – AIT – Austrian Institute of Technology – Austria; Pedro ALMEIDA, Stephane RAPOPORT, Frederik GETH – Tractebel Engineering – Belgium, CIRED 2015
- 5 The PlanGridEV Distribution Grid Simulation Tool with EV Models**
F. Geth et.al, – Abstract accepted at CIRED 2016, workshop
- 6 Impact of Electric Vehicles on Distribution Network Operation: Real World Case Studies**
P. Chittur Ramaswamy et.al, – Abstract accepted at CIRED 2016 workshop
- 7 Optimal multistage planning of LV networks with EV load control: prospective ICT vs traditional asset reinforcement investment**
Luís SILVESTRE, Susete ALBUQUERQUE – EDP Distribuição – Portugal; Alexandre DIAS, Pedro CARVALHO – IN-ESC ID – Portugal; Pedro ALMEIDA, Stéphane RAPOPORT – Tractebel Engineering – Belgium, 23rd International Conference on Electricity Distribution – Lyon, 15–18 June 2015
- 8 Mixed-Integer Second-Order Cone Unit Models for Combined Active-Reactive Power Optimization”**
Frederik Geth, Christophe del Marmol, David Laudy, Christian Merckx, submitted for IEEE Energycon, April 2016, Leuven, Belgium
- 9 PlanGridEV Approach for representing Electric Vehicles in Distribution Grid Planning – Proof of Concept**
Sawsan Henein, Stefan Übermasser, Antony Zegers, and Armin Gaul, DERlab Journal, no. Special Issue COTEVOS, 2015, PDF Download available
- 10 The Concept of Energy Traceability: Application to EV Electricity Charging by Res**
Fabio Orecchini, Adriano Santiangeli, F. Zuccari, A. Dell’Era ENERGY PROCEDIA 82:637-644, December 2015
- 11 Holistic Modelling Approach for Techno-Economic Evaluation of ICT Infrastructures for Smart Grids**
Nils DORSCH, Stefan BÖCKER, Christian HÄGERLING, Christian WIETFELD, In Proceedings of the 6th IEEE International Conference on Smart Grid Communications (SmartGridComm 2015), IEEE, Miami, USA, November 2015
- 12 EV Integration in Smart Grids Through Interoperability Solutions**
Raúl Rodríguez, Carlos Madina, Eduardo Zabala, EVS28, Kyntex, Korea, 1st May 2015
- 13 Assessment of ICT-based architectures for the integration of EVs in Smart Grids**
Raúl Rodríguez, Carlos Madina, Eduardo Zabala, European Battery, Hybrid and Fuel Cell Electric Vehicle Congress (EEVC 2015), Brussels, 2nd–4th December 2015



The research leading to these results has received funding from the European Union Seventh Framework Programme (FP7/2007–2013) under Negotiation No. 608957.



Responsible for the content of this publication is the PlanGridEV project coordinator.

RWE Deutschland AG

Dr. Armin Gaul, Project coordinator PlanGridEV
Kruppstr. 5, 45128 Essen, Germany
Telefon +49 201 12-29342
E-Mail armin.gaul@rwe.com
Website www.plangridev.eu

February 2016



